

# ***Bardac*** **drives Model 370 manual**

Copyright Bardac Corporation 2004  
Except for the purpose of supporting products sold by  
Bardac Drives, reproduction of all or any part of these  
documents is strictly prohibited.

Please read and understand this manual prior to installing the unit. Please obtain expert help if you are not qualified to install this equipment. Make the safety of your installation a priority. This component is hazardous.

**POWER RATING** For DC motors rated up to 0.37KW (0.5HP), armature voltage 90 to 180V max. (24 to 48V on model 370LV)

**MAXIMUM OUTPUT** Armature. 3.7 Amps continuous, 200V max.  
Field. 0.5 Amps at 0.9 X AC supply input voltage.

**AC SUPPLY INPUT** Model 370. 90-120V AC or 200-264V AC, 50 or 60Hz.  
Model 370LV. 25-35V AC or 50-70V AC. 50 or 60Hz.

**SPEED RANGE** Full Torque speed range 0 - 100%, dependant on motor rating,  
Full load regulation typically 0.1% (Tacho), 2% (Armature voltage).

## **USER ADJUSTMENTS**

Maximum Speed. 90 to 200V or 24 to 48V on model 370LV.

Minimum Speed. 0 to 30% of maximum speed.

Ramp. 1 to 20 seconds up ramp rate.

IR Comp. 0 to 25%

Current. 0 to 100% current limit. 0 to 3.7 Amps

*All presets rotate clockwise for linear increase in parameter.*

**EXTERNAL CONTROLS** Speed setpoint from external 10K ohm pot.  
External RUN contact for electronic stop / start.

**CONTROL ACTION** Speed loop: Full P+I armature voltage feedback.  
Current loop: Full P+I current shunt feedback.

## **INSTALLATION AND COMMISSIONING**

See page 3 for EMC installation guidelines for systems in the European Union.  
Ensure supply is disconnected before working on unit.

**POWER CABLING.** Use correctly rated cable minimum 600V AC, 1.5 times armature current

**FUSING.** Built in line fuse rated at 6.3A HRC ceramic. Do not replace with glass fuse type. The internal fuse is for wiring protection. The drive thyristor bridge can only be protected by fitting an external semiconductor fuse with I t<sup>2</sup> rating below 50. Contact the supplier for fuse information.

**CONTROL SIGNALS.** All control inputs to the drive are NON-ISOLATED. Do not connect any of the terminals to earth or other non-isolated equipment. A common cause of drive damage is accidental earthing of the external pot or run contact wiring. Avoid running signal cables close to power cables.

**MECHANICAL.** Optimise heatsink airflow. Avoid vibration and ambient temps outside -10C and +40C. Protect the drive from pollutants.

**MOTOR.** Foot mounted motors must be level and secure. Protect motors from ingress of foreign matter during installation. Ensure accurate alignment of motor shaft with couplings. Do not hammer pulleys or couplings onto the motor shaft. Before running the motor complete the following check list.

- 1) Correct insulation resistance between all windings and earth with all drive cables disconnected
- 2) Check inside connection box for foreign objects, damaged terminals etc.
- 3) Check that brushes are in good condition, correctly seated and free to move in brush boxes. Check correct action of brush springs.
- 4) Motor vents must be freed of any obstruction or protective covers prior to running.
- 5) **WARNING** reversing systems. Do not transpose the armature connections until the motor has stopped. Failure to heed this warning will cause damage.

**AC SUPPLY.** Ensure that the supply selection jumper on the drive matches the incoming supply. Failure to do this may result in permanent damage to the unit.

**PRESET POT SETTINGS.** Set the CURRENT preset to match the motor armature rating. Fully clockwise 3.7Amps fully anticlockwise zero. ie midway 1.8 Amps. Set all other presets fully anticlockwise.

**POWER ON.** Check ON lamp lights

**CLOSE RUN CONTACT.** Gradually increase external setpoint, check motor rotation. If the direction is wrong, TURN OFF and swap the connections to A+, A-.

**INCREASE SETPOINT** to maximum. Drive should ramp up to full speed. Fine adjust with MAX SPEED preset. Do not exceed armature voltage rating. Reduce setpoint, drive should coast down to zero. Adjust MIN SPEED to desired level. Run motor up and down and adjust RAMP.

**IR COMP.** Speed droop may occur where armature voltage feedback is used. This is compensated for by clockwise rotation of IR COMP preset. Excessive rotation may lead to instability. No IR COMP is required for systems with tacho feedback, its use will cause instability.

**Tacho Feedback.** Terminal 6 is for Tacho feedback input. In order to use Tacho feedback R1 must be removed (snipped out) and if necessary R32 must be changed to accommodate the full speed tacho voltage according to the table below.

| <b>Full speed tacho voltage.</b> | <b>Value of R32</b>                       |
|----------------------------------|---|
| 110 to 270V                      | 1M (Fitted as standard.)                  |
| 55 to 135V                       | 500K (1M soldered in parallel with R32)   |
| 22 to 67V                        | 250K (330K soldered in parallel with R32) |
| 10 to 25V                        | 91K (100K soldered in parallel with R32)  |

The negative tacho signal is input to terminal 6, the positive to terminal 4.(COM)

# INSTALLATION GUIDE FOR SYSTEMS USED IN THE EUROPEAN UNION

Special consideration must be given to installations in member states of the European Union regarding noise suppression and immunity. According to IEC 1800-3 (EN61800-3) the drive units are classified as complex components only for professional assemblers, with no CE marking for EMC. The drive manufacturer is responsible for the provision of installation guidelines. The resulting EMC behaviour is the responsibility of the manufacturer of the system or installation. The units are subject to the LOW VOLTAGE DIRECTIVE 73/23/EEC and are CE marked accordingly. CE

Following the procedures outlined below will normally be required for the drive system to comply with the European regulations, some systems may require different measures. Installers must have a level of technical competence to correctly install. Although the drive unit itself is not subject to the EMC directive, considerable development work has been undertaken to ensure that the noise emissions and immunity are optimised.

\* EN61800-3 specifies 2 alternative operating environments. These are the domestic (1st environment) and industrial (2nd environment). There are no limits specified for conducted or radiated emissions in the industrial environment, hence it is usual for the filter to be omitted in industrial systems.

Definition of an industrial environment. All establishments other than those directly connected to a low-voltage power supply network which supplies buildings used for domestic purposes.

## DRIVE INSTALLATION REQUIREMENTS FOR EMC COMPLIANCE

Keep parallel runs of power and control cables at least 0.3m apart. Crossovers must be at right angles

Keep sensitive components at least 0.3m from the drive and power supply cables

The AC connections from the filter to the drive must be less than 0.3m or if longer correctly screened

Do not run filtered and unfiltered AC supply cables together

Control signals must be filtered or suppressed eg control relay coils and current carrying contacts. The drive module has built in filters on signal outputs

The AC supply filter must have a good earth connection to the enclosure back plane. Take care with painted metal to ensure good conductivity.

The AC input filter has earth leakage currents. Earth RCD devices may need to be set at 5% of rated current

The metal enclosure will be the RF ground. The AC filter and motor cable screen should connect directly to the metal of the cabinet for best performance

Linear control signal cables must be screened with the screen earthed at the drive end only. Minimise the length of screen stripped back and connect it to an analogue earth point

The motor cable must be screened or armoured with 360 degree screen terminations to earth at each end. The cable must have an internal earth cable and the screen must extend into the enclosure and motor terminal box to form a Faraday cage without gaps

The internal earth cable must be earthed at each end. The incoming earth must be effective at RF. **WARNING!** the earth safety must always take precedence.

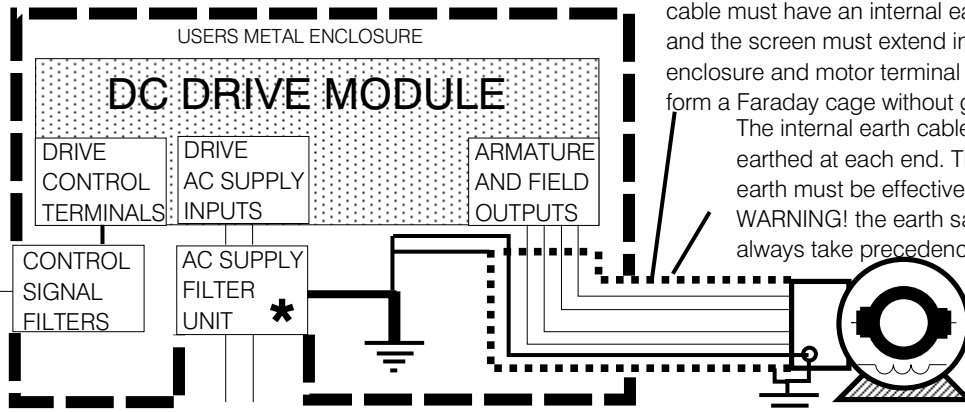

## IMPORTANT SAFETY WARNINGS

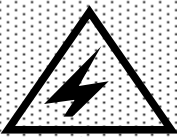

**DANGER**  
ELECTRIC SHOCK RISK

The AC supply filters must not be used on supplies that are un-balanced or float with respect to earth

The drive and AC filter must only be used with a permanent earth connection. No plugs/sockets are allowed in the AC supply

The AC supply filter contains high voltage capacitors and should not be touched for a period of 20 seconds after the removal of the AC supply

## MULTIPLE DRIVES WITH ONE FILTER AND EARTHING METHODS

The filter should be rated for the worst case total armature current load. The drive units are designed to function normally on unfiltered AC supplies shared with other thyristor DC drives. (not AC drives)

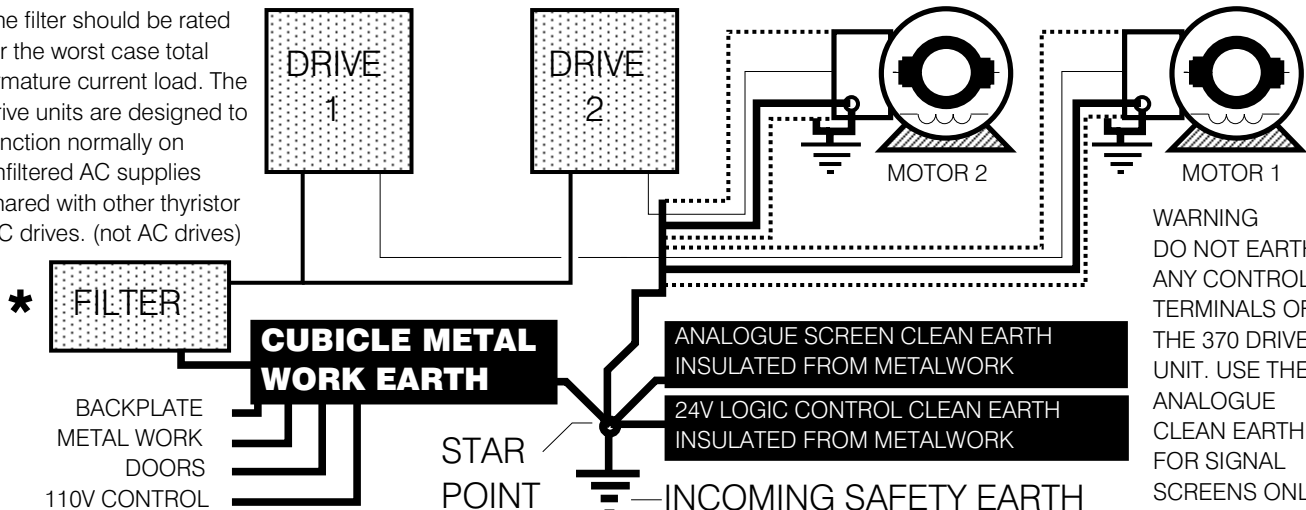

**WARNING**  
DO NOT EARTH ANY CONTROL TERMINALS OF THE 370 DRIVE UNIT. USE THE ANALOGUE CLEAN EARTH FOR SIGNAL SCREENS ONLY

**Terminal Listing.**      **Warning.** All terminals at high potential. Do not touch.

- 1 +10V output. 2mA max.
- 2 Min. (Bottom end on external pot.)
- 3 Input. This terminal accepts a 0 to +10V speed demand signal. It has a 39K internal pull down resistor.
- 4 Drive common.
- 5 RUN. internal 12K pull up resistor to +10V. Reset release time 0.1 to 0.5 secs
- 6 Tacho input (-ve)      *(WARNING. RUN is an electronic inhibit function. The field remains energised, and all power terminals remain 'live'. RUN must not be relied upon during hazardous operations)*
- A+ Motor armature +
- A- Motor armature -
- F- Motor field - (Note: No connection when using permanent magnet motor.)
- F+ Motor field + (for half wave field volts 0.45 times AC connect field to F- and N)
- N AC supply
- L AC Supply

For frequent stopping or jogging it is not good practice to rely on switching the supply off and on to stop and start with the run contact permanently closed. This may result in an uncontrolled current pulse for one half mains cycle under certain conditions. Eg main contact bounce. This could lead to undesired motor movement or device damage. Use a spare NO contact on the main supply contactor in series with T5 and any other RUN contacts in rapid start stop applications

In armature voltage feedback mode the tacho input may be used as an auxiliary speed input. It acts as an arithmetic summing junction with the main setpoint and has a strength of approximately 5%. (+/-10V input gives +/-5% speed change). This input bypasses the setpoint ramp stage and has a fast response.

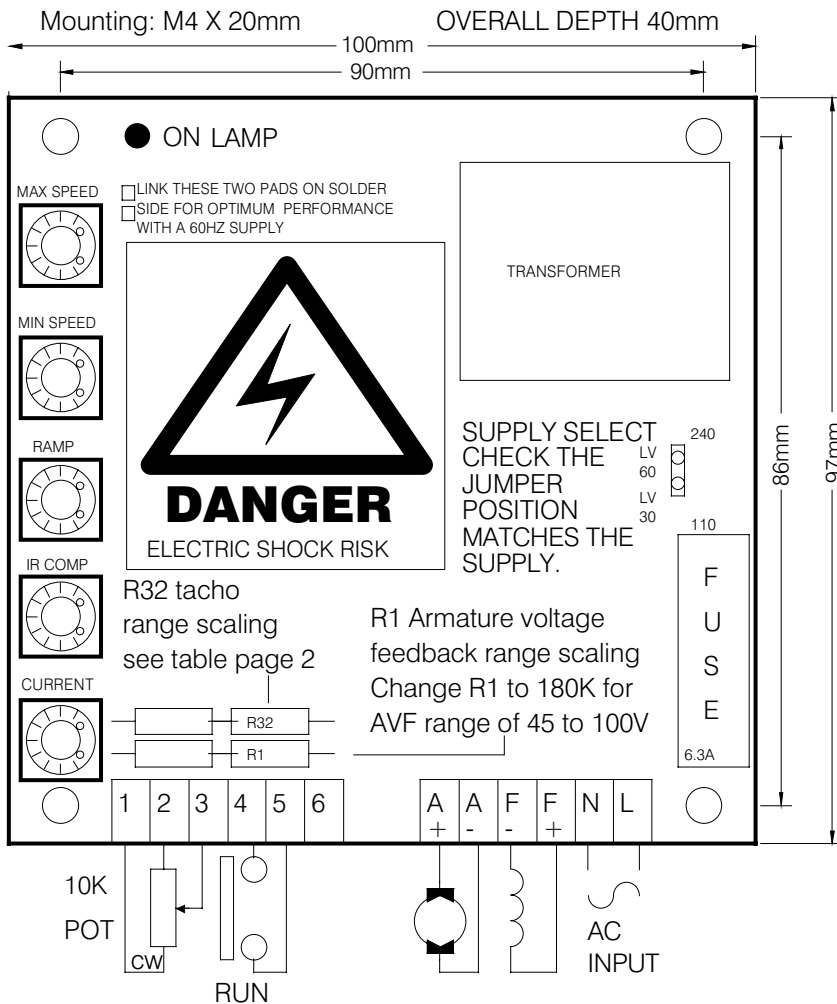

HEALTH AND SAFETY AT WORK. ELECTRICAL DEVICES CONSTITUTE A SAFETY HAZARD. IT IS THE RESPONSIBILITY OF THE USER TO ENSURE COMPLIANCE WITH ANY ACTS OR BYLAWS IN FORCE. ONLY SKILLED PERSONS SHOULD INSTALL THIS EQUIPMENT.

BARDAC CORP. DOES NOT ACCEPT ANY LIABILITY WHATSOEVER FOR THE INSTALLATION, FITNESS FOR PURPOSE OR APPLICATION OF ITS PRODUCTS. IT IS THE USERS RESPONSIBILITY TO ENSURE THE UNIT IS CORRECTLY USED AND INSTALLED.

***Bardac*** drives

**Bardac Corporation**  
**40 Log Canoe Circle**  
**Stevensville, MD 21666 USA**  
**Phone: (410)604-3400 Fax: (410)604-3500**  
**www.bardac.com**