

ISS	DATE	APPROVED
A	9 SEP 98	R. WILLIAMS
B	18 NOV 98	R. WILLIAMS
C		
D		
E		

THIRD ANGLE PROJECTION

*NOTE: LINE FILTER MUST BE MOUNTED WITH VENTILATION SLOTS TO THE TOP.
FUSE PROTECTION MAXIMUM RATING 15AMPS.

Bardac

40 Log Canoe Circle, Stevensville, MD 21666
phone: (410) 604-3400 fax: (410) 604-3500
email: info@bardac.com

SHT. TITLE	COMPONENT ASSEMBLY DETAIL	CUST.	DRN.	R. WILLIAMS 9 SEP 98	DWG. NO.	HJ501031
DWG. TYPE	ASSEMBLY DIAGRAM	DIST.	DESIGN		DWG. ISS.	A B
JOB TITLE	3 PHASE LINE FILTER ASSEMBLY	P.O.	SCALE	DO NOT SCALE	JOB NO.	
LOCATION			SIZE	A	SHT.	1 OF 1

1

2

3

4

A

A

B

B

C

C

D

D

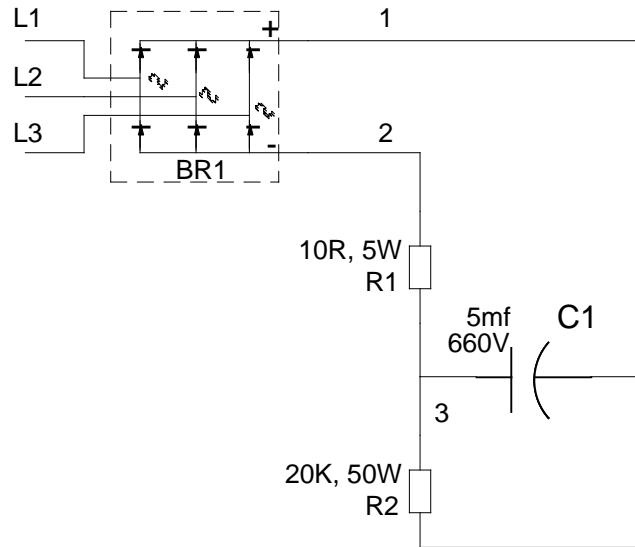

ISS	DATE	APPROVED
A		

SHT. TITLE	CONNECTION DIAGRAM	CUST.		DRN.	R. WILLIAMS 14 SEP 98	DWG. NO.	HF501031
DWG. TYPE		DIST.		DESIGN		DWG. ISS.	A
JOB TITLE	3 PHASE LINE FILTER	P.O.		SCALE	DO NOT SCALE	JOB NO.	
LOCATION		SIZE	A	SHT.	1	OF	1

Bardac

40 Log Canoe Circle, Stevensville, MD 21666
 phone (410) 604-3400 fax: (410) 604-3500
 email: info@bardac.com

1

2

3

4