



P2 & V3 Through Hole Mounting Kit Instructions

Overview

The Through Hole Mounting Kit allows P2 & V3 drives, Frame Size 4 – 7 to be mounted into a control cabinet with the rear heatsink mounted through the backplate of the control panel. This ensures that the hot air from the drive heatsink is kept separate from the control electronics and switchgear in the front of the cabinet.

Important Safety Information

This option is specifically designed to be used with the Optidrive variable speed drive product range and is intended for professional incorporation into complete equipment or systems. If installed incorrectly it may present a safety hazard. The Optidrive uses high voltages and currents, carries a high level of stored electrical energy, and is used to control mechanical plant that may cause injury. Close attention is required to system design and electrical installation to avoid hazards in either normal operation or in the event of equipment malfunction. Optidrive and the Options should be installed only by qualified electrical persons and in accordance with local and national regulations and codes of practice.

Electric shock hazard! Disconnect and **ISOLATE** the Optidrive before attempting any work on it. High voltages are present at the terminals and within the drive for up to 10 minutes after disconnection of the electrical supply.

Where the electrical supply to the drive is through a plug and socket connector, do not disconnect until 10 minutes have elapsed after turning off the supply.

It is the responsibility of the installer to ensure that the equipment or system into which the product is incorporated complies with the EMC legislation of the country of use. Within the European Union, equipment into which this product is incorporated must comply with 89/336/EEC, Electromagnetic Compatibility.

Within the European Union, all machinery in which this product is used must comply with the Directive 89/392/EEC, Safety of Machinery. In particular, the equipment should comply with EN60204-1.

The manufacturer accepts no liability for any consequences resulting from inappropriate, negligent or incorrect installation.

The contents of this User Guide are believed to be correct at the time of printing. In the interests of a commitment to a policy of continuous improvement, the manufacturer reserves the right to change the specification of the product or its performance or the contents of the User Guide without notice.

Mounting Dimensions

Part Number	Optidrive Size	Panel Cut Out Dimensions		Mounting Dimensions					
		H mm (in)	W mm (in)	A mm (in)	B mm (in)	C mm (in)	D mm (in)	E mm (in)	Mounting
T2-THMT04	4	425 (17.3)	180 (7.09)	228 (8.98)	110 (4.33)	110 (4.33)	521.5 (20.53)		4 x M8
T2-THMT05	5	515 (21.26)	240 (9.65)	292 (11.5)	175 (6.89)	175 (6.89)	612.5 (24.11)		4 x M8
T2-THMT06	6	815 (34.06)	335 (13.39)	398 (15.67)	200 (7.87)	200 (7.87)	924 (36.38)		4 x M10
T2-THMT07	7	1230 (50.4)	335 (13.39)	398 (15.67)	200 (7.87)	200 (7.87)	1342 (52.83)		4 x M10

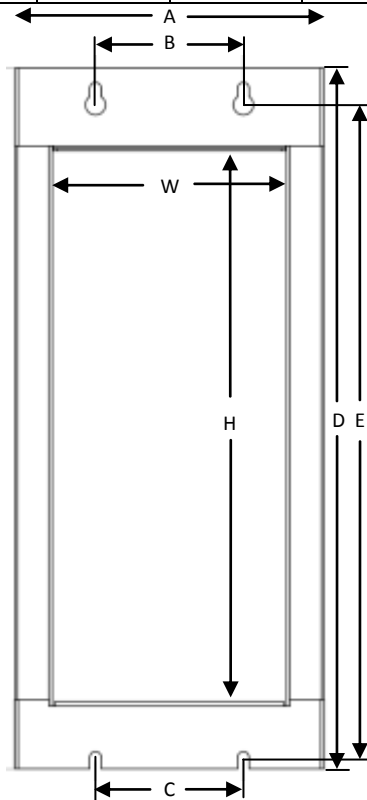

Installation-Frame Sizes 4 & 5

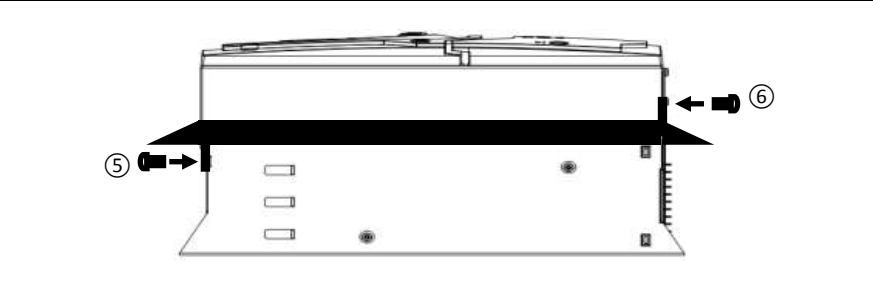
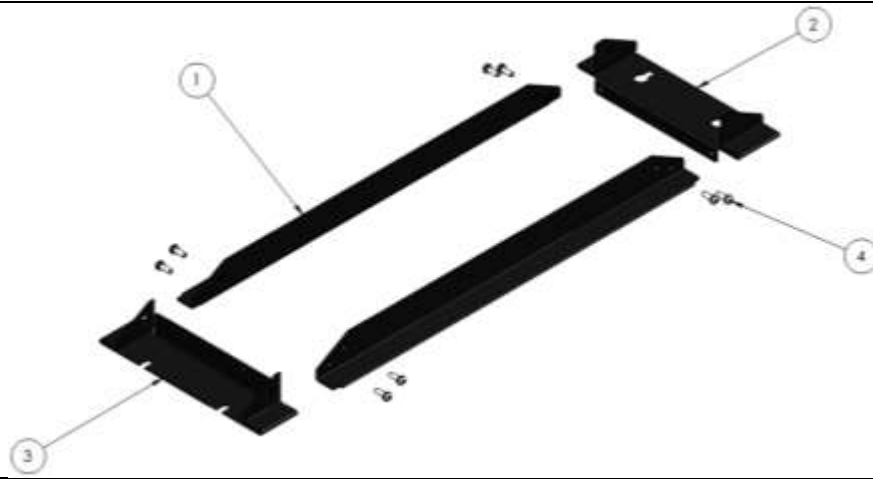

Parts List

Item No.	Description	Qty
1	Side bracket	2
2	Upper bracket	1
3	Lower bracket	1
4	M5 x 10mm machine screw c/w washers	8

Installation

1. Cut the hole in the panel backplate according to the dimensions in the table above
2. On the drive, remove the two Torx T20 screws on the rear of the top fan guard (5).
3. Remove the screws securing the gland plate to the drive. Any cable entry holes required should be cut into the gland plate whilst it is removed from the drive, and before reassembly begins.
4. Attach the Upper bracket (2) to the top of the drive using the Torx T20 screws (5) removed in step 2.
5. Attached the Side brackets to the top bracket using 4 x M5 screws (4).
6. Refit the gland plate to the drive, along with the Lower bracket. The gland plate should be mounted to the drive first, using only the front screws, then the Lower bracket attached using the rear gland plate screws (6).
7. Attach the Side brackets to the Lower bracket using 4 x M5 Screws (4).
8. Mount the drive into the control cabinet using 4 x M8 Bolts

Installation-Frame Sizes 6 & 7

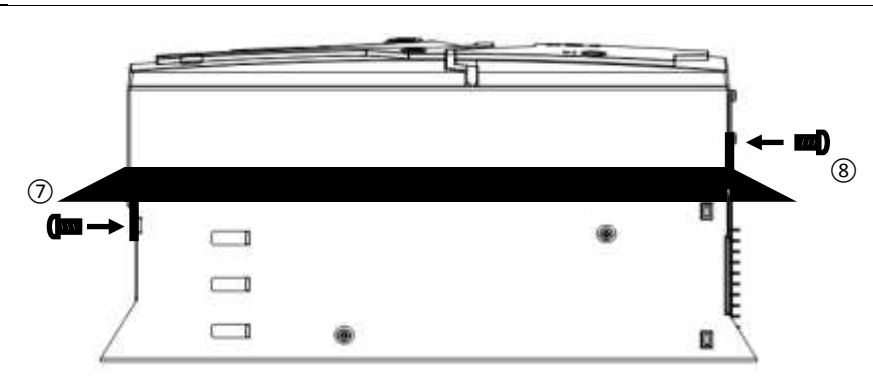
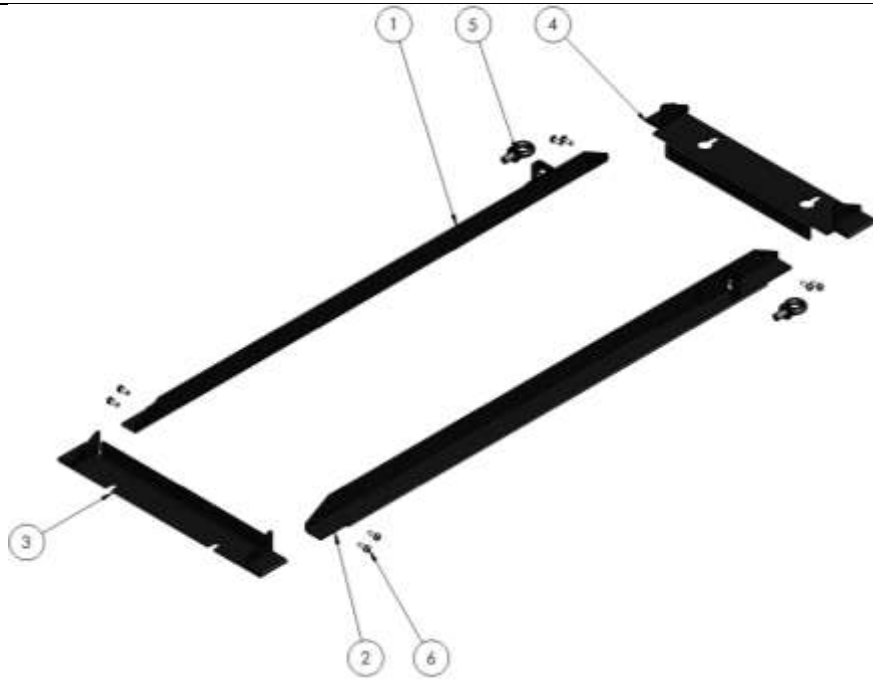

Parts List

Item No.	Description	Qty
1	Left side bracket	1
2	Right side bracket	1
3	Lower Bracket	1
4	Upper Bracket	1
5	M10 Eye Bolt	2
6	M5 x 10mm machine screw c/w washers	8

Installation

1. Cut the hole in the panel backplate according to the dimensions in the table above
2. On the drive, remove the two Torx T25 screws on the rear of the top fan guard (7).
3. Remove the screws securing the gland plate to the drive. Any cable entry holes required should be cut into the gland plate whilst it is removed from the drive, and before reassembly begins.
4. Attach the Upper bracket (2) to the top of the drive using the Torx T25 screws (7) removed in step 2.
5. Attached the Side brackets to the top bracket using 4 x M5 screws (4). Note that the Side brackets are left and right handed, the mounting for the lifting eye should be located nearest to the Upper bracket.
6. Refit the gland plate to the drive, along with the Lower bracket. The gland plate should be mounted to the drive first, using only the front screws, then the Lower bracket attached using the rear gland plate screws (8).
7. Attach the Side brackets to the Lower bracket using 4 x M5 Screws (4).
8. Attach the lifting eyes to the side brackets to allow easy lifting of the drive into place.
9. Mount the drive into the control cabinet using 4 x M10 Bolts