



Optidrive Applications Support Library

Application Note	AN-ODE-2-010
Title	Using the 2ROUT Option
Related Products	Optidrive E2
Level 1	1 – Fundamental - No previous experience necessary 2 – Basic – Some Basic drives knowledge recommended 3 – Advanced – Some Basic drives knowledge required 4 – Expert – Good experience in topic of subject matter recommended

Overview

The Optidrive E2 is designed with one standard user relay output. Where additional relays are required, the Optidrive E2 can be fitted with an option to extend the drives relay count to two user relay outputs. The part number for options module with extended relay functionality is given below:

Option Part Number	Additional Relays Provided	Notes
82-2ROUT-IN	1	Fitted to Optidrive E2 Control Terminal block



The second relay output replaces the analog output on the Optidrive E2 with a set of volt free contacts. The analog output is no longer available when using the option card

Second Relay Output Option (OPT-2ROUT-IN)

Pin Out Configuration

Terminal	Short Name	Long Name	Terminal Function
1	+24V	+ Supply Voltage (24V)	Normal Optidrive E2 Function
2	DI1	Digital Input 1	Normal Optidrive E2 Function
3	DI2	Digital Input 2	Normal Optidrive E2 Function
4	DI3 / AI2	Digital Input 3 / Analog Input 2	Normal Optidrive E2 Function
5	+10V	Potentiometer Supply (10V)	Normal Optidrive E2 Function
6	DI4 / AI1	Digital Input 4 / Analog Input 1	Normal Optidrive E2 Function
7	0V	0V User Ground	Normal Optidrive E2 Function
8	RL2-C	Relay 2 Output Common	Relay contacts, 250V AC, 30V DC, 5A
9	RL2-NO	Relay 2 Output NO	Relay contacts, 250V AC, 30V DC, 5A
10	RL1-C	Relay 1 Output Common	Relay contacts, 250V AC, 30V DC, 5A
11	RL1-NO	Relay 1 Output NO	Relay contacts, 250V AC, 30V DC, 5A

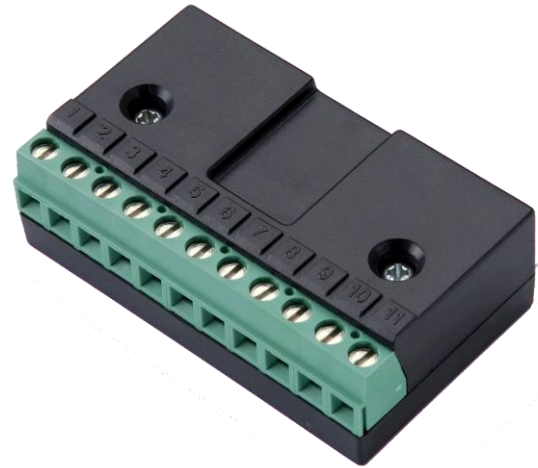
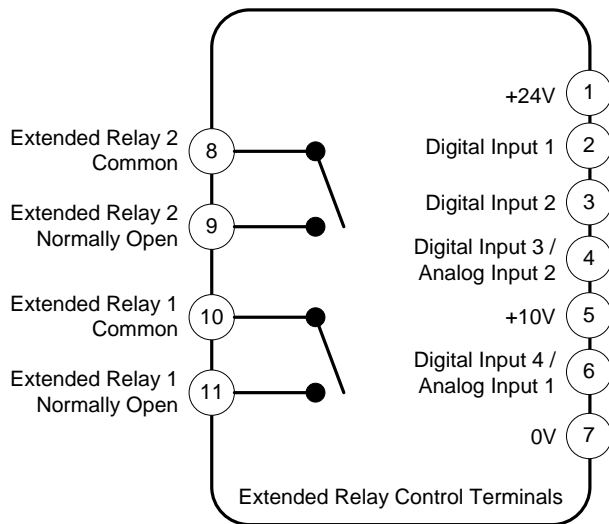

The Option module is fitted to pins 1 - 11 on the drive control terminal block of the Optidrive E2.

Parameter Configuration

The condition under which the second relay contacts open / close are determined by parameter P-25, which previously (prior to the option module being fitted to the drive) controlled the analog / digital output on terminal 8.

P-25 Analog / Digital output function select

To determine when this second relay opens / closes, P-25 needs to be set accordingly. The functionality of the analog output is set by this parameter. The following options are available, all of which configure the analog output as a digital output:

P-25	Function	Explanation
0	Drive Enabled	The relay contacts close when the drive enable signal is present and the drive has gone to an enabled state (i.e. no trip or fault present).
1	Drive Healthy	The relay contacts close when the drive is powered up and no fault exists. If the power is removed, or the drive trips, the relay contacts will open.
2	Motor At Target Speed	The relay contacts close when the drive output frequency matches the requested set-point frequency.
3	Drive tripped	The relay contacts are open when the drive is powered up and no fault exists. If the drive trips the relay contacts will close.
4	Output Frequency \geq limit	The relay contacts close when the output frequency of the drive is greater than the limit programmed in P-19 and reopens when the output frequency falls below the level programmed in P-19.
5	Motor Current \geq limit	The relay contacts close when the output current of the drive is greater than the limit programmed in P-19 and reopens when the output current falls below the level programmed in P-19.
6	Output Frequency $<$ limit	The relay contacts close when the output frequency of the drive is below the limit programmed in P-19 and reopens when the output frequency goes above the level programmed in P-19.
7	Motor Current $<$ limit	The relay contacts close when the output current of the drive is below the limit programmed in P-19 and reopens when the output current goes above the level programmed in P-19.



Note that options 8, 9 in P-25 cannot be used to control the relay, as these are analog outputs.

P-19 Relay Adjustable Threshold Limit

This parameter is used to define the closing and opening level (limit) for the output relays (1 & 2) where the switching point is a variable or adjustable value. The parameter is active when P-25 is set to a value between 4 and 7.

The adjustable threshold parameter is set as a percentage of the function selected in P-25. The percentage values set relate to the following drive values:

P-25	Function	P-19 Settings
4	Output Frequency \geq limit	P-19 is set as a percentage of P-01 (Motor Maximum Speed).
5	Motor Current \geq limit	P-19 is set as a percentage of P-08 (Motor Rated Current).
6	Output Frequency $<$ limit	P-19 is set as a percentage of P-01 (Motor Maximum Speed).
7	Motor Current $<$ limit	P-19 is set as a percentage of P-08 (Motor Rated Current).

Example

If P-25 is set to '4' (Output Frequency \geq limit) then P-19 is set as a percentage of P-01 (Motor Maximum Speed).

Assuming P-01 = 50Hz, P-19 = 50.0%, then relay 2 contacts will close when the output frequency is equal or above 25.0Hz, and reopens when the output frequency is less than 25.0 Hz.



Note that parameter P-19 is active for both user relay 1 and user relay 2 simultaneously. When one or the other relays are configured with a value between 4 & 7 then the opposing relay should be assigned a digital function (value between 0 and 3).

Appendix:

Revision History			
Issue	Comments	Author	Date
01	Document Creation	JP	08/02/12
02	Revised to new format	KB	24/04/14