



## Optidrive Applications Support Library

|                          |   |
|--------------------------|---|
| <b>Application Note</b>  | <b>AN-ODE-2-025</b>   |
| <b>Title</b>             | <b>Remote Push-Button Speed Control</b>   |
| <b>Related Products</b>  | <b>Optidrive E2</b>   |
| <b>Level</b><br><b>2</b> | 1 – Fundamental - No previous experience necessary<br>2 – Basic – Some Basic drives knowledge recommended<br>3 – Advanced – Some Basic drives knowledge required<br>4 – Expert – Good experience in topic of subject matter recommended |

### Overview

For some applications it can be preferable to control the speed of a motor by increasing and decreasing speed using push-button controls mounted on a control panel or operator station, sometimes referred to as Digital Potentiometer Speed Control. This application note describes two examples of how this can be implemented on the Optidrive E2.

### Solution One Wiring Diagram

The Following circuit uses a standard single pole switch for start and stop control with momentary push buttons to increase and decrease speed.

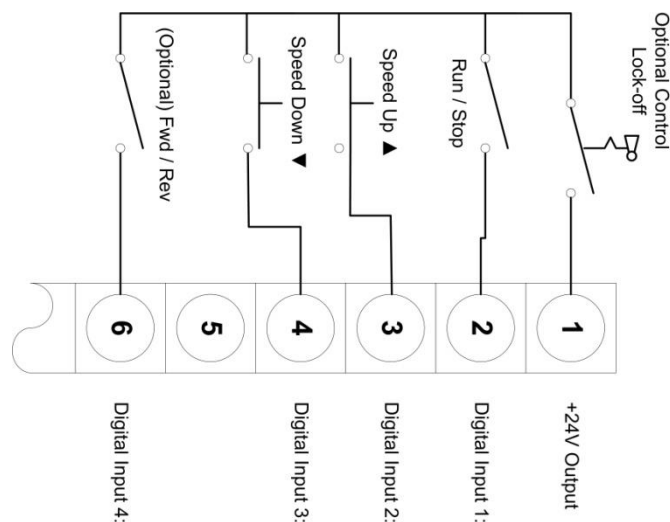

### Solution One Operation

The optional lock off provides a useful feature which stops operation of all of the other input functions and prevents operation of the drive when in the open position. It could be provided as a key switch or a lock off on the control panel. The start mode for the drive is set to edge triggered so that the start input must always be applied after the control lock-off is disabled (closed). This input should not be used as a safety related input for the application. In the event of any safety related issues the drive should be fully isolated from the mains supply.

The Run/Stop input provides a Run command to the drive when the switch is in the closed position and a Stop when the switch is open.

The Speed Up and Speed Down are momentary push buttons that are held in to increase or decrease the speed reference to the drive.

The Fwd / Rev switch is optional depending on whether bi-directional (forward and reverse) motor rotation is required. The drive operates in the forward direction when the switch is open and reverses when the switch closes.

### Solution One parameter Set-up

The drive should be defaulted back to factory settings prior to set-up. The following parameters are set within the drive to activate the functionality shown in the control diagram. Check all parameters have been set correctly prior to enabling the drive. Note that Parameter P-14 must be set to the value listed in the table before access will be permitted to parameters higher in order than P-14.

#### Parameter Changes:

| Par  | Description                  | Value  | Notes  |
|------|------------------------------|--------|--|
| P-12 | Primary Command Source       | 1      |  |
| P-14 | Extended Menu Access code    | 101    |  |
| P-31 | Keypad Mode Restart Function | 2 or 3 | Settings 2 and 3 allow the drive to be started from the control terminals directly and implement the functionality shown in the control diagram.<br>Settings 2 causes the drive to always start at the Minimum Frequency (P-02)<br>Settings 3 causes the drive to always start at the last operating Frequency |

### Solution Two Wiring Diagram

The Following circuit uses a standard momentary switch for both start and stop control and for the push buttons to increase and decrease speed. The start push button has two spate normally open contacts.

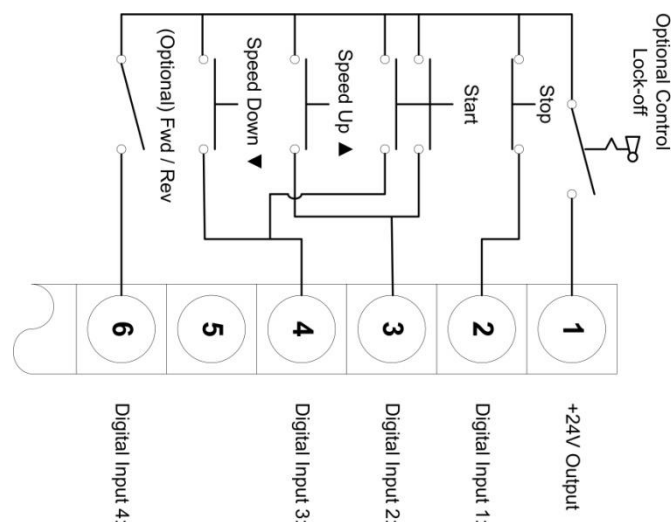

### Solution Two Operation

Fully detail of the optional lock off is provided in solution one operation description.

The Stop input is a normally closed momentary switch that provides a stop command to the drive when opened. The drive will stop when this switch is activated (opened) and will prevent the drive starting whilst held in the open position. The switch is a normally closed configuration to help protect against wire-break in the control circuitry.

The Start input is a normally open momentary switch that provides a start command to the drive (by operating the speed up and speed down inputs simultaneously). The Run input is latched so that the switch can be released once the drive is started and will continue to run until over-written by a stop input.

The Speed Up and Speed Down are momentary push buttons that are held in to increase or decrease the speed reference to the drive.

The Fwd / Rev switch is optional depending on whether bi-directional (forward and reverse) motor rotation is required. The drive operates in the forward direction when the switch is open and reverses when the switch closes.

## Solution Two parameter Set-up

The drive should be defaulted back to factory settings prior to set-up. The following parameters are set within the drive to activate the functionality shown in the control diagram. Check all parameters have been set correctly prior to enabling the drive.

Note that Parameter P-14 must be set to the value listed in the table before access will be permitted to parameter numbers higher in order than P-14.

### Parameter Changes:

| Par  | Description                  | Value  | Notes   |
|------|------------------------------|--------|---|
| P-12 | Primary Command Source       | 1      |   |
| P-14 | Extended Menu Access code    | 101    |   |
| P-31 | Keypad Mode Restart Function | 0 or 1 | Settings 0 and 1 allow the drive to be started from the control terminals directly or from the keypad and implement the functionality shown in the control diagram.<br>Settings 0 causes the drive to always start at the Minimum Frequency (P-02)<br>Settings 1 causes the drive to always start at the last operating Frequency |

### Notes on Remote Push-button Speed Control:

The rate of change of the set-point is pre-set within the drive to match the ramp rates set in P1-03 (acceleration ramp) and P1-04 (deceleration ramp) and cannot be adjusted independently. Therefore, as the ramp rate parameters are increased / decreased, the rate of change of the motor set-point is correspondingly altered. The frequency shown on the drive display should match closely the drive output speed to the motor at any given time.

The momentary push buttons for increasing and decreasing the speed set-point are mirrored by the up and down push buttons on the drive keypad. The Stop / Start keypad buttons are also active and can be used to stop or stop the drive directly.

If both speed set-point push buttons (increase and decrease) are operated simultaneously then the decrease speed button will over-ride the functionality of the increase speed push button and the speed set-point will decrease.

## Appendix

| Revision History |                       |        |          |
|------------------|-----------------------|--------|----------|
| Issue            | Comments              | Author | Date     |
| 01               | Document Creation     | JP     | 22/02/12 |
| 02               | Revised to new format | KB     | 24/04/14 |