



Optidrive Applications Support Library

Application Note	AN-ODV-2-038
Title	Modbus RTU Control & Register Mapping
Related Products	Optidrive HVAC
Level 1	1 – Fundamental - No previous experience necessary 2 – Basic – Some Basic drives knowledge recommended 3 – Advanced – Some Basic drives knowledge required 4 – Expert – Good experience in topic of subject matter recommended

Overview:

This document provides information on the Modbus RTU memory mapping that is implemented in the Optidrive HVAC drives, detailing which addresses are used to read and write data to / from the Optidrive in a Modbus RTU network. All data registers within the drive are Holding Registers, and can be accessed by means of the Modbus commands 03 Read Multiple Holding Registers and 06 Write Single Register only.

The Modbus Request PDU specifies the starting register address and the number of registers. In this case, with some Modbus Master Systems, it may be necessary to subtract 1 from the register number (e.g. some systems treat holding register 1 as address 0).

Inverttek Drives Ltd adopts a policy of continuous improvement and whilst every effort has been made to provide accurate and up to date information, the information contained in this document should be used for guidance purposes only and does not form the part of any contract.

MODBUS RTU Protocol Specification:

The following table highlights the specification for the Modbus RTU implementation.

Protocol	Modbus RTU
Error check	CRC
Baud rate (P-36)	Parameter Selectable as follows :- 9600bps, 19200bps, 38400bps, 57600bps, 115200bps (default)
Data format	Parameter Selectable as follows : 1 start bit, 8 data bits, 1 stop bits, no parity. (default) 1 start bit, 8 data bits, 2 stop bits, no parity. 1 start bit, 8 data bits, 1 stop bits, even parity. 1 start bit, 8 data bits, 1 stop bits, odd parity.
Physical signal	RS 485 (2-wire)

Modbus Telegram Structure:

The following Modbus Commands are supported

- 03 Read Multiple Holding Registers
- 06 Write Single Holding Register

The telegram structure is as follows:-

Command 03 – Read Holding Registers					
Master Telegram			Slave Response		
Field	Length	Unit	Field	Length	Unit
Slave Address	1	Byte	Slave Address	1	Byte
Function Code (03)	1	Byte	Function Code (03)	1	Byte
1st Register Address	2	Bytes	Byte Count	1	Byte
No. Of Registers	2	Bytes	1st Register Value	2	Bytes
CRC Checksum	2	Bytes	2nd Register Value	2	Bytes
			Etc...		
			CRC Checksum	2	Bytes

Command 06 – Write Single Holding Register					
Master Telegram			Slave Response		
Field	Length	Unit	Field	Length	Unit
Slave Address	1	Byte	Slave Address	1	Byte
Function Code (06)	1	Byte	Function Code (06)	1	Byte
Register Address	2	Bytes	Register Address	2	Bytes
Value	2	Bytes	Register Value	2	Bytes
CRC Checksum	2	Bytes	CRC Checksum	2	Bytes

RJ45 Data Connection Pin Configuration:

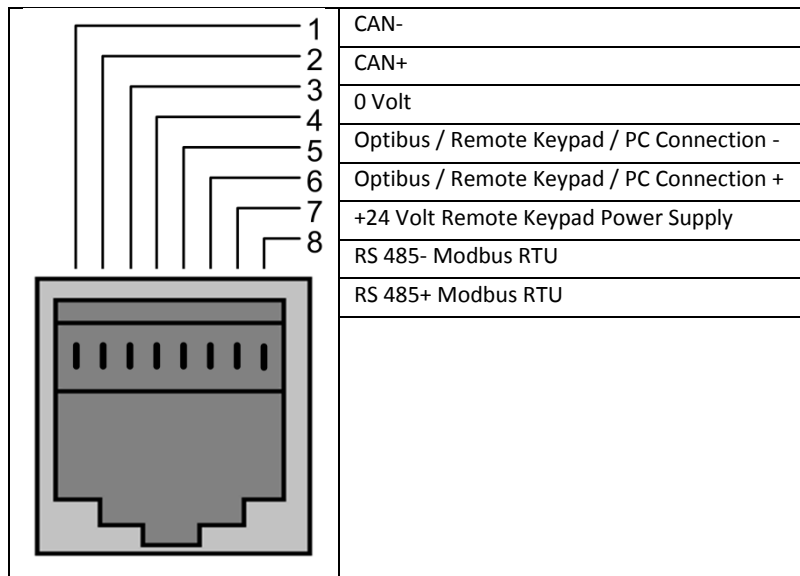

Register Map

Table 1: Control and status registers

Register	Upper byte	Lower Byte	Command	Type	Scaling
1	Drive Control Command Word		03, 06	Read/Write	
2	Frequency Setpoint (Reference)		03, 06	Read/Write	500 = 50.0 Hz
3	Reserved				
4	Modbus ramp control time		03, 06	Read/Write	3000 = 30.00 Seconds
5	Reserved				
6	Error code	Drive status	03	Read Only	
7	Output Frequency		03	Read Only	500 = 50.0Hz
8	Output Current		03	Read Only	100 = 10.0 Amps
9	Reserved				
10	Output Power		03	Read Only	1000 = 10.00kW
11	Digital Input Status		03	Read Only	
12	Rating ID		03	Read Only	
13	Power rating		03	Read Only	
14	Voltage rating		03	Read Only	
15	IO Processor Software Version		03	Read Only	100 = 1.00
16	Motor Control Processor Software Version		03	Read Only	100 = 1.00
17	Drive Type		03	Read Only	
18	Reserved				
19	Reserved				
20	Analog Input 1 Signal Level		03	Read Only	1000 = 100.0%
21	Analog Input 2 Signal Level		03	Read Only	1000 = 100.0%
22	Pre Ramp Speed Reference (Hz)		03	Read Only	

Register	Upper byte	Lower Byte	Command	Type	Scaling
23	DC bus Voltage		03	Read Only	600 = 600 Volts
24	Drive Temperature		03	Read Only	40 = 40°C
25	Drive Serial Number 4		03	Read Only	
26	Drive Serial Number 3		03	Read Only	
27	Drive Serial Number 2		03	Read Only	
28	Drive Serial Number 1		03	Read Only	
29	Relay Output Status		03	Read Only	
30	kWh meter (User)		03	Read Only	100 = 10.0kWh
31	MWh meter (User)		03	Read Only	100 = 100MWh
32	kWh Meter		03	Read Only	
33	MWh Meter		03	Read Only	
34	Running time – hour		03	Read Only	
35	Running time – min/sec		03	Read Only	
36	Running time since last enable – hour		03	Read Only	
37	Running time since last enable – min/sec		03	Read Only	
38	Service time (hours)		03	Read Only	
39	Room (Control PCB) temperature		03	Read Only	
40	Reserved				
41	Reserved				
42	Digital pot reference value		03	Read Only	
43	P0-80		03	Read Only	
44	Parameter Number		06	Read/Write	
45	Parameter Value		06	Read/Write	

Internal Register Access area

Register	Upper byte	Lower Byte	Command	Type	Scaling
51	User register 1		03, 06	Read/Write	
52	User register 2		03, 06	Read/Write	
53	User register 3		03, 06	Read/Write	
54	User register 4		03, 06	Read/Write	
55	User register 5		03, 06	Read/Write	
56	User register 6		03, 06	Read/Write	
57	User register 7		03, 06	Read/Write	
58	User register 8		03, 06	Read/Write	
59	User register 9		03, 06	Read/Write	
60	User register 10		03, 06	Read/Write	
61	User register 11		03, 06	Read/Write	
62	User register 12		03, 06	Read/Write	
63	User register 13		03, 06	Read/Write	
64	User register 14		03, 06	Read/Write	
65	User register 15		03, 06	Read/Write	
66	Analog output 1 user		03, 06	Read/Write	
67	Analog output 2 user		03, 06	Read/Write	
68	Reserved		03, 06	Read/Write	
69	Reserved		03, 06	Read/Write	
70	Relay output 1 user		03, 06	Read/Write	
71	Relay output 2 user		03, 06	Read/Write	
72	Relay output 3 user		03, 06	Read/Write	
73	Relay output 4 user		03, 06	Read/Write	
74	Relay output 5 user		03, 06	Read/Write	
75	User display scaling		03, 06	Read/Write	
76	User display decimal		03, 06	Read/Write	
77	User speed reference		03, 06	Read/Write	
78	User torque reference		03, 06	Read/Write	
79	User ramp		03, 06	Read/Write	
80	Scope index 1, 2		03, 06	Read/Write	

Control and Status Register Descriptions:

Read and write registers

Register 1: Drive Control Command Word

15	14	13	12	11	10	9	8	7	6	5	4	3	2	1	0
High byte								Low byte							

Bit 0: Run/Stop command: Set to 1 to enable (run) the drive. Set to 0 to disable (stop) the drive.

Bit 1: Fast stop request. When set to 1 the drive will decelerate to stop using the 2nd deceleration ramp (P2-25).

Bit 2: Reset Fault Request. Set to 1 in order to reset the drive following a trip / fault.

(Note: This bit must be reset to zero once the fault is cleared to prevent un-expected reset)

Bit 3: Coast stop request. Set to 1 to issue a coast stop command.

For normal operation, Bit 3 has the highest priority, bit 0 has the lowest priority (bit 3>bit 1>bit 0). For example if the control word is set to 0x0009 by the network master, the drive will do a coast stop rather than run. For normal Start / Stop operation, bit 0 should be used.

Register 2: Modbus Speed Reference Setpoint

This register is used to send the speed reference value. The input data is a 16bit signed integer including one decimal place. For example, a value of 500 represents a speed reference of 50.0Hz, 123 represents 12.3Hz. It is also possible to reverse the drive by sending a negative value in this register. For example, -1(0xFFFF) gives -0.1Hz. -234(0xFF16) gives -23.4Hz.

The input value range is from -5000 +5000; however the actual drive output frequency will be limited by the minimum and maximum frequencies set in P1-02 and P1-01 respectively.

Register 4: Modbus Ramp Control Time

This register specifies the drive acceleration and deceleration ramp time simultaneously. This value will override the values set in parameters P1-03 and P1-04 respectively, providing P5-08 = 1. The input data range is from 0 to 60000 (0.00s to 600.00s)

Read only registers

Register 6: Drive status and error code

High byte: Shows the last drive error / fault code. (Valid when the drive is tripped, a list of error codes is shown later in this document)

Low byte: Shows the drive operating status as follows

Bit	Logic 0	Logic 1	Note
0	Drive Stopped	Drive Enabled	Indicates when the drive is enabled, including enabled but in Standby Mode
1	Drive Healthy	Drive Fault (Tripped)	Indicates when the drive has tripped
2	Auto Control Mode	Hand Control Mode	Indicates if Hand or Auto operation is selected
3	STO OK	STO Inhibit	Indicates the status of the STO / Inhibit hardware circuit
4		Maintenance Time Reached	Indicates when the programmable maintenance time has been reached
5	Normal Operation	Standby	Indicates when the drive is in Standby Mode
6	No Function		
7	No Function		

Register 7: Output Frequency

This register shows the output frequency.

The data is 16bit integer with one decimal place. E.g. value 123 gives 12.3Hz. Value -234 (0xFF16) gives -23.4Hz.

Register 8: Output Current

This register displays the output current from the drive.

The data is 16bit integer with one decimal place. E.g. 156 = 15.6A, 12 = 1.2A.

Register 10: Output Power

This register displays the output power level.

The data is 16bit integer with two decimal places. E.g. 1000 = 10.00kW

Register 11: Digital input status

The value in this register represents the digital status of the drive control input terminals. Bit 0 indicates the status of Input 1; Bit 1 indicates the status of Input 2 etc...

Register 12: Rating ID

The value in this parameter includes specific drive ID information, and is not recommended to be used by customer. For more information regarding this parameter, please contact Invertek Drives Ltd directly.

Register 13: Power rating

This gives the drive power rating information to two decimal places, e.g. 075 = 0.75. The unit of this register depends on the drive type (KW/HP)

Register 14: Supply Voltage level

This register gives the rated input voltage for the drive.

i.e. 230: 230V nominal (200 – 240 + / - 10%)

400: 400V nominal (380 – 480 + / - 10%)

460: 460V nominal (380 – 480 Volts + / - 10%)

Register 15: IO software version

This register contains the drive IO software version info. The value includes two decimal places.

i.e. 100 means version 1.00

Register 16: Motor control processor software version

This register contains the software version info of the motor control processor. The value includes two decimal places. E.g. 100 means version 1.00

Register 17: Drive type

This register gives the drive internal type code.

Register 20: Analog input 1 value

This register gives the value of the analog signal applied to analog input 1 after any scaling and offsets have been applied. The value is a 16 bit integer where a returned value of 4096 represents the maximum input value, e.g. 100%.

Register 21: Analog input 2 value

This register gives the value of the analog signal applied to analog input 2 after any scaling and offsets have been applied. The value is a 16 bit integer where a returned value of 4096 represents the maximum input value, e.g. 100%.

Register 22: Pre Ramp Speed Reference Value

This register contains the reference speed information that being used by the drive for motor speed control. The data is in Hz and with one decimal place (i.e. 234 = 23.4Hz)

Register 23: DC bus voltage

This register contains drive internal DC bus voltage information. The value is displayed as volts, with no decimal places.

Register 24: Drive temperature

This register contains drive temperature information. Data is in Celsius with no decimal place.

Registers 44 & 45: Drive Parameter Write Access

These two registers can be used together to allow writing of any parameter within the drive.

Register 44 should firstly be set to the parameter number, e.g. to change the value of P1-01, set register 44 = 101.

Register 45 should then be set to the value which should be written to the parameter. When the value of Register 45 changes, the parameter value is written, such that changes to parameter values are triggered by changing Register 45 only, and not by changing Register 44.

An error response will be returned in the following cases:-

- Writing to a parameter number which does not exist
- Writing a value outside of the parameter range
- Attempting to change a parameter whilst the drive is enabled if that parameter is locked during operation

Drive Parameters

All User Adjustable parameters in Groups 1 to 8 can be accessed by Modbus. For further details regarding the parameter functions, please refer to the Optidrive HVAC User Guide.

Register Type definitions are defined as follows

WORD Hexadecimal Word

U16 Unsigned 16 Bit Value

S16 Signed 16 Bit Value

Group 1: Basic Parameter Set (Level 1)

Parameter	Register Number	Description	Range	Scaling	Type
P1-01	101	Max Frequency Limit	0 to 7200	3000 = 50.0Hz	U16
P1-02	102	Min Frequency Limit	0 to 7200 (Limited by P1-01)	3000 = 50.0Hz	U16
P1-03	103	Acceleration Ramp Time	0 to 6000	300 = 30.0s	U16
P1-04	104	Deceleration Ramp Time	0 to 6000	300 = 30.0s	U16
P1-05	105	Stop mode	0: Ramp to Stop 1: Coast to Stop		U16
P1-06	106	Energy optimiser	0: Disable 1: Enable		U16
P1-07	107	Motor rated voltage	0V, 20V to 250V 0V, 20V to 500V 0V, 20V to 600V	230 = 230 V	U16
P1-08	108	Motor rated current	20% to 100% of drive rated current	1 = 0.1A	U16
P1-09	109	Motor rated frequency	25 to 500Hz	50 = 50Hz	U16
P1-10	110	Motor rated speed	0 to 30 000rpm	1500 = 1500rpm	U16
P1-11	111	V/F Voltage Boost	Auto, 0.1 to 20%	-1 = Auto 0 = Disabled 1 = 0.1%	S16
P1-12	112	Control mode	0: Terminal mode 1: Keypad mode (Unipolar) 2: Keypad mode (Bipolar + direction toggle) 3: User PID mode 4: Fieldbus (Modbus, Profibus etc.) 5: Slave mode		U16
P1-13	113	Digital inputs function select	0: User defined 1...13 See User Guide Table		U16
P1-14	114	Extended Menu Access code	0 to 30 000		U16

Group 2: Extended parameter set (Level 2)

Parameter	Register Number	Description	Range	Scaling	Type
P2-01	201	Preset speed 1	-7200 to 7200 (Limited by P1-01)	3000 = 50.0Hz	S16
P2-02	202	Preset speed 2	-7200 to 7200 (Limited by P1-01)	3000 = 50.0Hz	S16
P2-03	203	Preset speed 3	-7200 to 7200 (Limited by P1-01)	3000 = 50.0Hz	S16
P2-04	204	Preset speed 4	-7200 to 7200 (Limited by P1-01)	3000 = 50.0Hz	S16
P2-05	205	Preset speed 5	-7200 to 7200 (Limited by P1-01)	3000 = 50.0Hz	S16
P2-06	206	Preset speed 6	-7200 to 7200 (Limited by P1-01)	3000 = 50.0Hz	S16
P2-07	207	Preset speed 7	-7200 to 7200 (Limited by P1-01)	3000 = 50.0Hz	S16
P2-08	208	Preset speed 8	-7200 to 7200 (Limited by P1-01)	3000 = 50.0Hz	S16
P2-09	209	Skip frequency centre point	0 to 7200 (Limited by P1-01)	3000 = 50.0Hz	S16
P2-10	210	Skip frequency band	0 to 7200 (Limited by P1-01)	3000 = 50.0Hz	S16
P2-11	211	Analog output 1 function select	Digital Mode (0V or 24V only) 0: Drive running 1: Drive healthy 2: Motor at target speed 3: Motor Speed > 0 4: Motor Speed > limit 5: Motor Current > limit 6: Motor Torque > limit 7: 2 nd Analog input > limit (Limit set by P2-18, P2-19) Analog Mode 8: Speed 9: Current 10: Torque 11: Power		U16
P2-12	212	Analog output 1 format	0 = 0...10V 1 = 10...0V 2 = 0-20mA 3 = 20-0mA 4 = 4-20mA 5 = 20-4mA		U16
P2-13	213	Analog output 2 function select	Digital Mode (0V or 24V only) 0: Drive running 1: Drive healthy 2: Motor at target speed 3: Motor Speed > 0 4: Motor Speed > limit 5: Motor Current > limit 6: Motor Torque > limit 7: 2 nd Analog input > limit (Limit set by P2-18, P2-19) Analog Mode 8: Speed 9: Current 10: Torque 11: Power		U16
P2-14	214	Analog output 2 format	0 = 0...10V 1 = 10...0V 2 = 0-20mA 3 = 20-0mA 4 = 4-20mA 5 = 20-4mA		U16
P2-15	215	User relay 1 output function select	0: Drive running 1: Drive healthy 2: Motor at target speed 3: Motor Speed > 0 4: Motor Speed > limit 5: Motor Current > limit 6: Motor Torque > limit 7: 2 nd Analog input > limit		U16
P2-16	216	User relay 1 upper limit	P2-17 to 2000	1 = 0.1%	U16
P2-17	217	User relay 1 lower limit	0 to P2-16	1 = 0.1%	U16

Parameter	Register Number	Description	Range	Scaling	Type
P2-18	218	User relay 2 output function select	0: Drive running 1: Drive healthy 2: Motor at target speed 3: Motor Speed > 0 4: Motor Speed > limit 5: Motor Current > limit 6: Motor Torque > limit 7: 2 nd Analog input > limit		U16
P2-19	219	User relay 2 upper limit	P2-20 to 2000	1 = 0.1%	U16
P2-20	220	User relay 2 lower limit	0 to P2-19	1 = 0.1%	U16
P2-21	221	Display scaling factor	0 to 30000	1 = 0.001	U16
P2-22	222	Display scaling source	0: Motor Speed 1: Motor Current 2: 2 nd Analog input		U16
P2-23	223	Zero Speed holding time	0 to 600	1 = 0.1	U16
P2-24	224	Effective switching frequency	0 = 4kHz 1 = 8kHz 2 = 12kHz 3 = 16kHz 4 = 24kHz 5 = 32kHz		U16
P2-25	225	Fast deceleration ramp time	0 to 3000	1 = 0.1s	U16
P2-26	226	Spin start enable	0: Disabled 1: Enabled	1	U16
P2-27	227	Standby mode	0 to 2500	1 = 0.1	U16
P2-28	228	Slave speed scaling control	0: Disabled 1: Preset by slave speed scaling 2: P2-33 scaling + analog in1 offset 3: P2-33 scaling + analog in1 scaling		U16
P2-29	229	Slave Speed scaling factor	-5000 to 5000	1 = 0.1	S16
P2-30	230	Analog input 1 format	0 = 0-10V 1 = 10-0V 2 = -10-10V, 3 = 0-20mA, 4 = t 4-20mA, 5 = r 4-20mA, 6 = t 20-4mA, 7 = r 20-4mA		U16
P2-31	231	Analog input 1 scaling	0 to 5000	1 = 0.1	U16
P2-32	232	Analog input 1 offset	-5000 to 5000	1 = 0.1	S16
P2-33	233	Analog input 2 format	0 = 0-10V 1 = 10-0V 2 = PTC Thermistor 3 = 0-20mA, 4 = t 4-20mA, 5 = r 4-20mA, 6 = t 20-4mA, 7 = r 20-4mA		U16
P2-34	234	Analog input 2 scaling	0 to 5000	1 = 0.1	S16
P2-35	235	Analog input 2 offset	-5000 to 5000	1 = 0.1	U16
P2-36	236	Start mode select	0 = Edge-r 1 = Auto-0 2 = Auto-1 3 = Auto-2 4 = Auto-3 5 = Auto-4 6 = Auto-5		U16
P2-37	237	Keypad restart speed	0: Minimum speed 1: Previous keypad speed 2: Current running Speed 3: Preset Speed 8		U16
P2-38	238	Mains loss stop control	0: Mains loss ride through 1: Coast to Stop 2: Fast ramp to stop		U16
P2-39	239	Parameter Lock	0: Unlocked 1: Locked		U16
P2-40	240	Extended parameter access code definition	0 ... 9 999		U16

Group 3: User PID control (Level 2)

Parameters	Register Number	Description	Range	Scaling	Type
P3-01	301	User PID Proportional Gain	1 to 300	1 = 0.1	U16
P3-02	302	User PID Integral time constant	0 to 300	1 = 0.1	U16
P3-03	303	User PID Differential time constant	0 to 100	1 = 0.01	U16
P3-04	304	User PID operating mode	0: Direct 1: Inverse		U16
P3-05	305	User PID reference select	0: Digital preset (P3-06) 1: 1 st Analog input 2: 2 nd Analog input		U16
P3-06	306	User PID digital reference	0 to 1000	1 = 0.1%	U16
P3-07	307	User PID controller output high limit	P3-08 to 1000	1 = 0.1%	U16
P3-08	308	User PID controller output low limit	0 to P3-07	1 = 0.1%	U16
P3-09	309	User PID output control	0: Digital output limits 1: 1 st Analog variable upper limit 2: 1 st Analog variable lower limit 3: PID output + 1 st analog input		U16
P3-10	310	User PID feedback select	0: 2 nd Analog input 1: 1 st Analog input		U16
P3-11	311	PID error to enable ramps	0 to 250	1 = 0.1%	U16
P3-12	312	PID feedback value display scaling factor	0 to 50000	0: Disabled 1 = 0.001	U16
P3-13	313	PID feedback wake-up level	0 to 1000	1 = 0.1%	U16
P3-14	314	Standby Active Speed	0 to 7200 (Limited by P1-01)	3000 = 50.0Hz	U16

Group 4: Motor control parameter set (Level 2)

Par	Register Number	Description	Range	Scaling	Type
P4-02	402	Motor parameter auto-tune	0: Disable 1: Enable		U16

Group 5: Fieldbus communications (Level 2)

Par	Register	Description	Range	Scaling	Type
P5-01	501	Fieldbus drive address	0...63	1 = 1	U16
P5-03	503	Modbus baudrate	0 = 9.6kbps, 1 = 19.2kbps, 2 = 38.4kbps, 3 = 57.6kbps, 4 = 115 kbps		U16
P5-04	504	Modbus data format	0 = N-1: No Parity 1 stop bit 1 = N-2: No parity 2 stop bits 2 = O-1: Odd parity 1 stop bit 3 = E-1: Even parity 1 stop bit		U16
P5-05	505	Comms loss timeout	0...0.1... 5.0	1 = 0.1s	U16
P5-06	506	Communications loss action	0: Trip 1: Ramp to Stop then trip 2: Ramp to stop (No trip) 3: Preset speed 8	1 = 1	U16
P5-07	507	Fieldbus ramp control	0: Disable 1: Enable	1 = 1	U16
P5-08	508	Anybus module output process data 4	1: Power (x.xx kW) 2: Digital input status 3: 2 nd analog input (%) 4: Power stage temperature	1=1	U16

Group 6: Advanced Parameter set (Level 3)

Par	Register	Description	Range	Scaling	Type
P6-01	601	Firmware Upgrade enable	0: Disabled 1: Enable (IO and DSP) 2: Enable (IO only) 3: Enable (DSP only)		U16
P6-02	602	Auto thermal management	0: Disable 1: Enable		U16
P6-03	603	Auto-reset delay time	1 to 60		U16
P6-04	604	User relay hysteresis band	0 - 250	1 = 0.1%	U16
P6-08	608	Max speed ref frequency	0, 5 to 20		U16
P6-10	610	Enable PLC operation	0: Disable 1: Enable		U16
P6-11	611	Speed hold time on enable	0 to 2500	1 = 0.1s	U16
P6-12	612	Speed hold time on disable	0 to 2500	1 = 0.1s	U16
P6-18	618	DC injection braking voltage	0: Auto 0 to 250	0 = Auto 1 = 0.1%	U16
P6-22	622	Reset cooling fan run-time	0: Disable 1: Enable		U16
P6-23	623	Reset kWh meter	0: Disable 1: Enable		U16
P6-24	624	Service time interval	0 ... 60 000 h (0 = disabled)	1=1	U16
P6-25	625	Reset service indicator	0: Disable 1: Reset	1=1	U16
P6-26	626	Analog output 1 scaling	0 to 5000	1 = 0.1	U16
P6-27	627	Analog output 1 offset	-5000 to 5000	1 = 0.1%	S16
P6-28	628	PO-80 display value index	0 to 127		U16
P6-29	629	Save User Parameters as default	0: Disable 1: Enable		U16
P6-30	630	Level 3 access code	0 to 9999		U16

Group 7: Motor Control Parameter set (Level 3)

Parameter	Register Number	Description	Range	Scaling	Type
P7-01	701	Motor Stator resistance	Drive dependent	1 = 0.001ohm	U16
P7-04	704	Motor Magnetising Current	Drive dependent	1 = 0.1A	U16
P7-11	711	Pulse width minimum limit	0 to 500 (Time = value *16.67ns)	1 = 1	U16
P7-12	712	V/F mode magnetising period	0 to 2000		U16

Group 8: Application Specific Parameters - Level 3

Parameter	Register Number	Description	Range	Scaling	Type
P8-01	801	Stir Function Interval Time	0 to 6000		U16
P8-02	802	Stir Activity Time	1 to 6000		U16
P8-03	803	Pump Clean Function Configuration	0: Disabled 1: Active on Start Only 2: Active on Torque Detection Only 3: Active on Start & Over Torque Detection		U16
P8-04	804	Clean Time interval	0 to 600		U16
P8-05	805	Pump Clean Function Ramp Time	0 to 60000	1 = 0.1s	U16
P8-06	806	Load Profile Monitor Function Enable	0: Disabled 1: Low Load Detection 2: High Load Detection 3: Low & High Load Detection		U16
P8-07	807	Load Profile Monitoring Bandwidth	10 to 1000	10 = 1.0A	U16
P8-08	808	Load Profile Monitoring Trip Delay	0 to 60		U16
P8-09	809	Fire Mode Logic	0: Open Activation (Normally Closed) 1: Closed Activation (Normally Open)		U16
P8-10	810	Fire Mode Speed	-7200 to 7200 (Limited by P1-01)	3000 = 50.0Hz	S16
P8-11	811	Bypass Mode on Fault	0: Disabled 1: Enabled		U16
P8-12	812	Bypass Mode on Fire	0: Disabled 1: Enabled		U16
P8-13	813	Bypass Contactor Changeover Time	0 to 300	1 = 0.1 s	U16
P8-14	814	Pump Staging Function Select	0: Disabled 1: Single Drive, Fixed Speed Assist 2: Multi Drive Optiflow Control		U16
P8-15	815	Pump Staging Additional Pumps	0 to 4		U16
P8-16	816	Pump Staging Duty Switchover Time	0 to 1000		U16
P8-17	817	Pump Staging DOL Switch in speed	0 to 7200 (Limited by P1-01)	3000 = 50.0Hz	U16
P8-18	818	Pump Staging DOL Switch out speed	0 to 7200 (Limited by P1-01)	3000 = 50.0Hz	U16
P8-19	819	Pump Staging System Settle Time	10 to 600		U16
P8-20	820	Pump Staging Master Clock Reset	0: No Function 1: Reset Timer		U16

Drive Error Code Information

In the event of a trip, an error code is returned in the High Byte of the drive status word. The fault values correspond to the following table.

Fault Code	No.	Description	Fault Code	No.	Description
no-Flt	00	No Fault	AtF-01	40	Measured motor stator resistance varies between phases.
Ol-b	01	N/A	AtF-02	41	Measured motor stator resistance is too large.
OL-br	02	N/A	AtF-03	42	N/A
O-I	03	Instantaneous over current	AtF-04	43	N/A
I.t-trp	04	Motor Thermal Overload (I2t)	AtF-05	44	N/A
SAFE-1	05	Safety input circuit error (Processor output)	AtF-06	45	Reserved
O-Volt	06	Over voltage on DC bus	AtF-07	46	Reserved
U-Volt	07	Under voltage on DC bus	AtF-08	47	Reserved
O-t	08	Heatsink over temperature	AtF-09	48	Reserved
U-t	09	Under temperature	AtF-10	49	Reserved
P-dEF	10	Factory Default parameters have been loaded	SC-F01	50	Modbus comms loss fault
E-trip	11	External trip	SC-F02	51	BACNet comms loss trip
SC-ObS	12	Optibus comms loss	SC-F03	52	Anybus module comms loss trip
FLt-dc	13	DC bus ripple too high	SC-F04	53	IO card comms loss trip
P-LOSS	14	Input phase loss trip	SC-F05	54	Reserved
h O-I	15	Instantaneous over current on drive output.	SC-F06	55	Reserved
th-Flt	16	Faulty thermistor on heatsink.	SC-F07	56	Reserved
dAtA-F	17	Internal memory fault. (IO)	SC-F08	57	Reserved
4-20 F	18	4-20mA Signal Lost	SC-F09	58	Reserved
dAtA-E	19	Internal memory fault. (DSP)	SC-F10	59	Reserved
U-dEF	20	User Default Parameters Loaded	OF-01	60	Internal link to option module loss
F-Ptc	21	Motor PTC thermistor trip	OF-02	61	Option module in exceptional condition
FAN-F	22	Cooling Fan Fault	OF-03	62	Reserved
O-hEAt	23	Environmental temperature too high	OF-04	63	Reserved
O-torq	24	Over torque (HVAC)	OF-05	64	Reserved
U-torq	25	Under torque (HVAC)	OF-06	65	Reserved
Out-F	26	Drive output fault	OF-07	66	Reserved
Err-01	27	Reserved	OF-08	67	Reserved
Err-02	28	Reserved	OF-09	68	Reserved
SAFE-2	29	Safety input circuit error (Buffer output)	OF-10	69	Reserved
Enc-01	30	N/A	PLC-01	70	Unsupported PLC function block
Enc-02	31	N/A	PLC-02	71	PLC program over size
Enc-03	32	N/A	PLC-03	72	Divide by 0
Enc-04	33	N/A	PLC-04	73	Lower limit large than higher limit
Enc-05	34	N/A	PLC-05	74	Table function block index overflow
Enc-06	35	N/A	PLC-06	75	Reserved
Enc-07	36	N/A	PLC-07	76	Reserved
Enc-08	37	N/A	PLC-08	77	Reserved
Enc-09	38	N/A	PLC-09	78	Reserved
Enc-10	39	N/A	PLC-10	79	Reserved

Modbus Exception Response Telegrams

Under some circumstances, the drive may reply with an Exception Response (error) in response to a request telegram sent from the network master, for example where the master tries to read a register which does not exist. Exception Responses which can be generated by the drive are listed below:-

Exception Code 1: Invalid Request

Returned under the following conditions

- Network Master sends an unsupported Modbus command (e.g. Read Coils).
- Run command issued to drive whilst the drive is not set for Modbus Control Mode (e.g. P1-12 <>4).
- Run command issued to drives whilst the drive is not enabled (e.g. Digital Input 1 is open).
- Run command issued to drive whilst the drive is in a tripped condition.

Exception Code 2: Invalid Modbus register

Returned under the following conditions

- Network Master attempts to read or write a register that does not exist within the drive.

Exception Code 3: Register Value Out of Range

Returned under the following conditions

- Network Master attempts to write a holding register with a value outside the range of the register

Exception Code 6: Drive Busy

Returned under the following conditions

- Drive busy due to internal data transfer. The Network Master should re-send the message after a delay

Dataflow example

Read data from register 6:

Request:	[01]	[03]	[00] [05]	[00] [01]	[94] [0B]
	(Drive Addr)	(Command)	(Reg start addr)	(No. of Registers)	(Checksum)
Reply:	[01]	[03]	[02]	[00] [00]	[B8] [44]
	(Drive Addr)	(Command)	(No of data bytes)	(Data)	(Checksum)

Note: The actual start address of register 6 is 5. All data in [] is in 8bits Hex format.

Write start command to the register 1 (suppose P-12 = 3, P-15 =0 and digital input 1 is closed):

Request:	[01]	[06]	[00] [00]	[00] [01]	[48] [0A]
	(Drive Addr)	(Command)	(Reg addr)	(Data value)	(Checksum)
Reply:	[01]	[06]	[00] [00]	[00] [01]	[48] [0A]
	(Drive Addr)	(Command)	(Reg addr)	(Data value)	(Checksum)

Note: The actual address of register 1 on the data link is 0. All data in [] is in 8bits Hex format.

Reply can be error message depending on drive parameter settings and digital input status.

Appendix

Revision History			
Issue	Comments	Author	Date
01	First Release	KB	27/10/11
02	Added Modbus Error Response details. Corrected data flow example	KB	15/02/12
03	Register 6 definition updated	KB	10/10/13
04	Updated to new format Standby bit added in Register 6 Added Register 44 & 45 definition and usage	KB	28/04/14