



40 Log Canoe Circle, Stevensville, MD 21666
 (410) 604-3400 | bardac.com | driveweb.com

APPLICATION NOTE

Drive Applications Support Library

Application Note	AN-P2-006
Title	Configuring Voltage and Current Reference Inputs
Related Products	P2 Series AC Drives
Level: 1	<ul style="list-style-type: none"> 1 - Fundamental - No previous experience necessary. 2 - Basic - Some basic drives knowledge recommended. 3 - Advanced - Some basic drives knowledge required. 4 - Expert - Good experience in topic of subject matter recommended.

Overview:

The speed and Torque of the P2 Series drives can be controlled by either voltage based or current based reference signals. These signals can originate from a locally mounted potentiometer or from a remote intelligent control system (such as a PLC).

In addition the analog reference values fed back to the drive can be used within the drives PLC programming functionality (Licensed option) to represent feedback or values to the internal PLC program.

This applications note explains how the analog reference values are connected to the drive and how the drive is configured to understand the format of the signal it is receiving.

Parameters:

P2-30: Analog Input 1 (Terminal 6) Format

This parameter allows the user to configure the format of the signal connected to analog input 1. The following formats are supported:

U 0-10	Voltage input, 0V ... 10V (Uni-polar)
U 10-0	Voltage input, 10V ... 0V (Uni-polar)

- 10- 10	Voltage input, -10V ... 10V (Bi-polar)
A 0-20	Current input, 0mA ... 20mA
t 4-20	Current input, 4mA ... 20mA – Drive trip below 3mA
r 4-20	Current input, 4mA ... 20mA – Drive Stop below 3mA
t 20-4	Current input, 20mA ... 4mA – Drive trip below 3mA
r 20-4	Current input, 20mA ... 4mA – Drive Stop below 3mA

When set to 0-10V or 10-0V, all negative voltages will give zero speed. When set to -10-10V all negative voltages will result in the drive running with negative (reverse) speed. Speed is proportional to the magnitude of the input voltage in both directions.

Typical configurations for the analog input (Terminal 6) are shown below.

Example 1: Local Potentiometer using drive internal supply voltage.

P2 drives are configured with the internal +10V uni-polar supply for connection to a local Potentiometer.

P2-30 = U 0- 10, U 10- 0

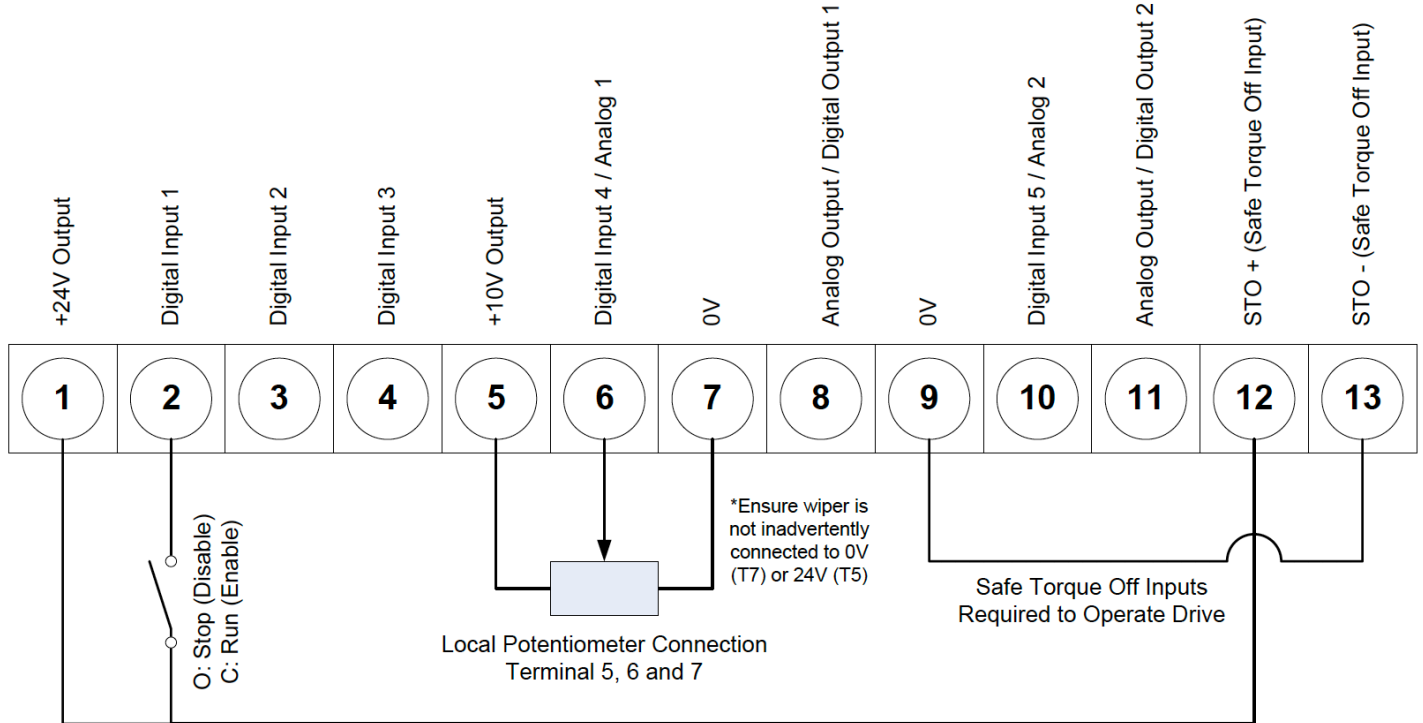

Example 2: Remote Signal Reference (voltage Source).

P2-33 = **U 0-10, U 10-0** (Matched to source)

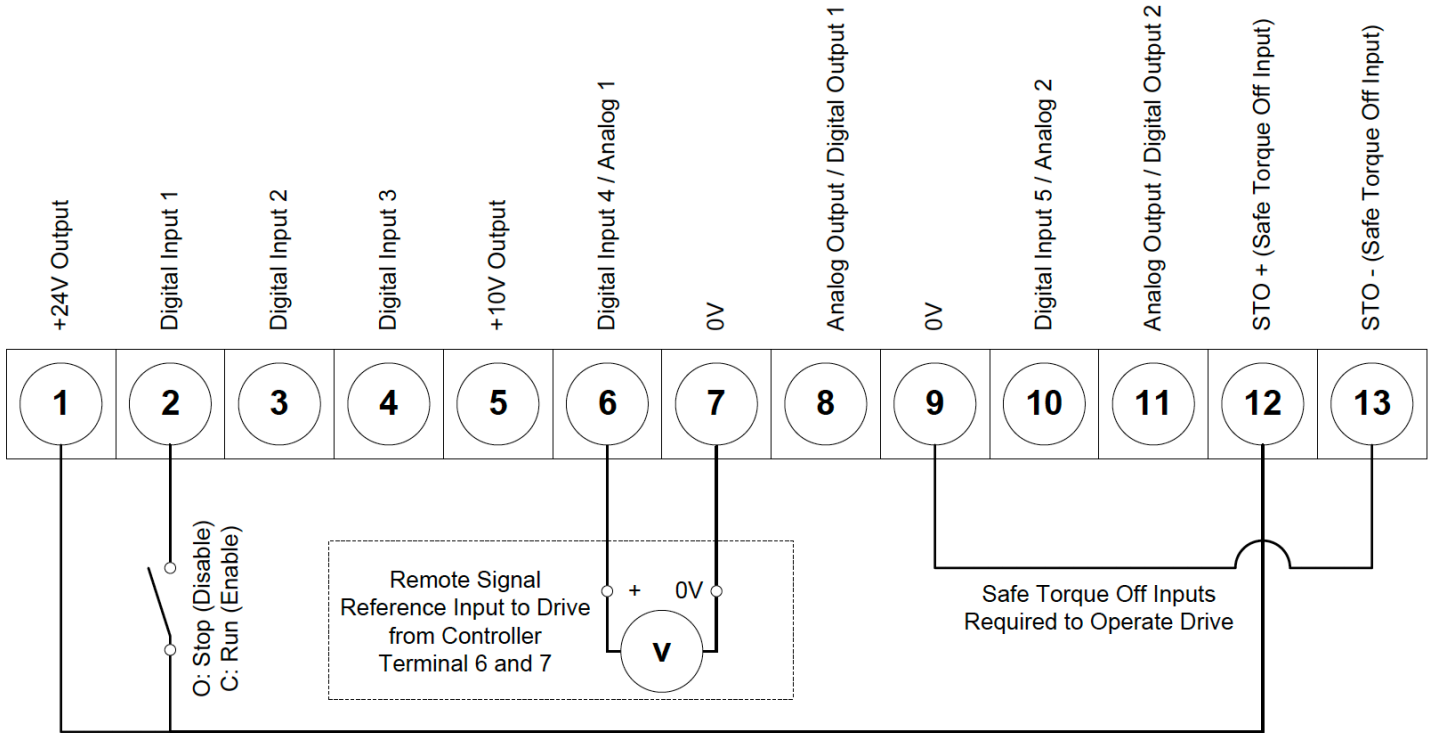

Example 3: Remote Signal Reference (Current Source).

P2-33 = **A 0-20, t 4-20, r 4-20, t 20-4, r 20-4** (Matched to source)

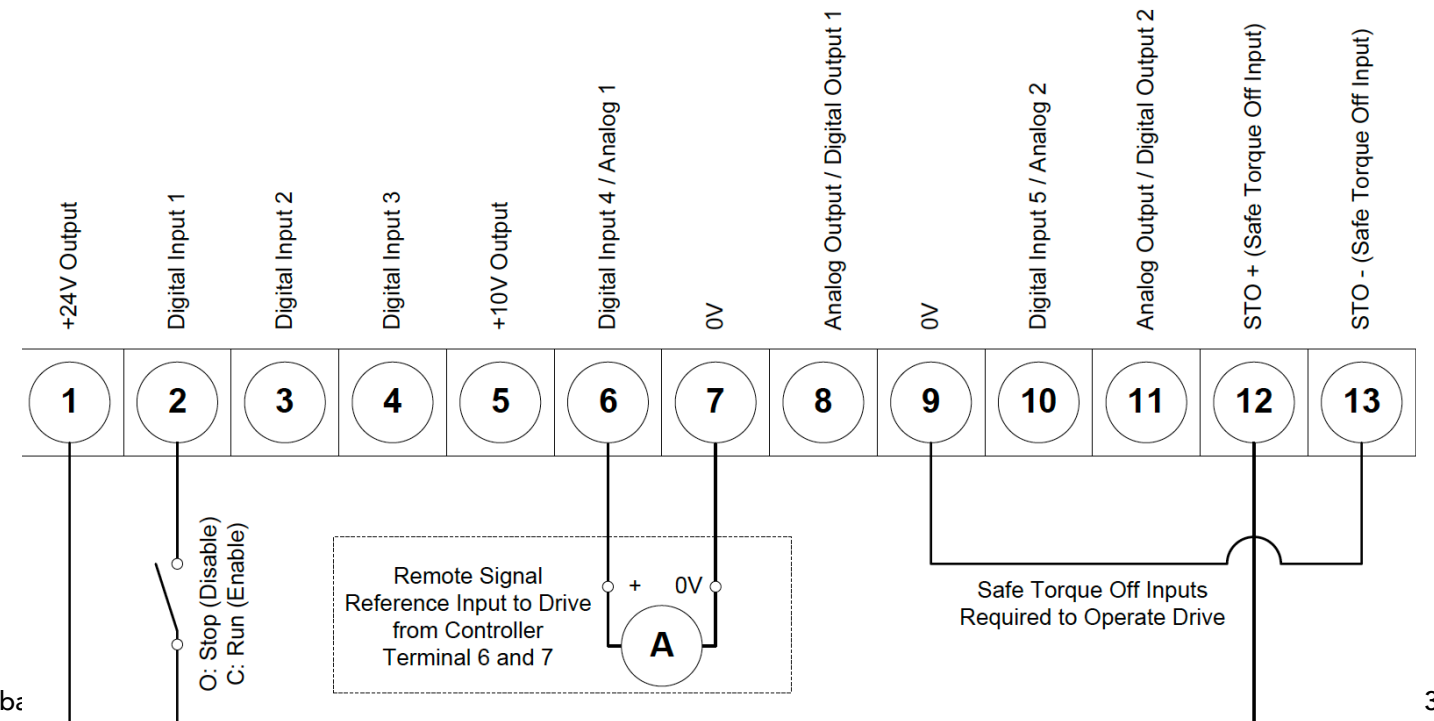

P2-33: Analog Input 2 (Terminal 10) Format

This parameter allows the user to configure the format of the signal connected to analog input 2. The following formats are supported:

<i>U 0-10</i>	Voltage input, 0V ... 10V (Uni-polar)
<i>U 10-0</i>	Voltage input, 10V ... 0V (Uni-polar)
<i>Ptc-th</i>	Motor PTC Thermistor Input
<i>A 0-20</i>	Current input, 0mA ... 20mA
<i>t 4-20</i>	Current input, 4mA ... 20mA – Drive trip below 3mA
<i>r 4-20</i>	Current input, 4mA ... 20mA – Drive Stop below 3mA
<i>t 20-4</i>	Current input, 20mA ... 4mA – Drive trip below 3mA
<i>r 20-4</i>	Current input, 20mA ... 4mA – Drive Stop below 3mA

When set to 0-10V or 10-0V, all negative voltages will give zero speed.

Typical configurations for the analog input (Terminal 10) are shown below.

Example 1: Local Potentiometer using drive internal supply voltage.

P2 drives are configured with the internal +10V uni-polar supply for connection to a local Potentiometer.

P2-33 = **U 0-10, U 10-0**

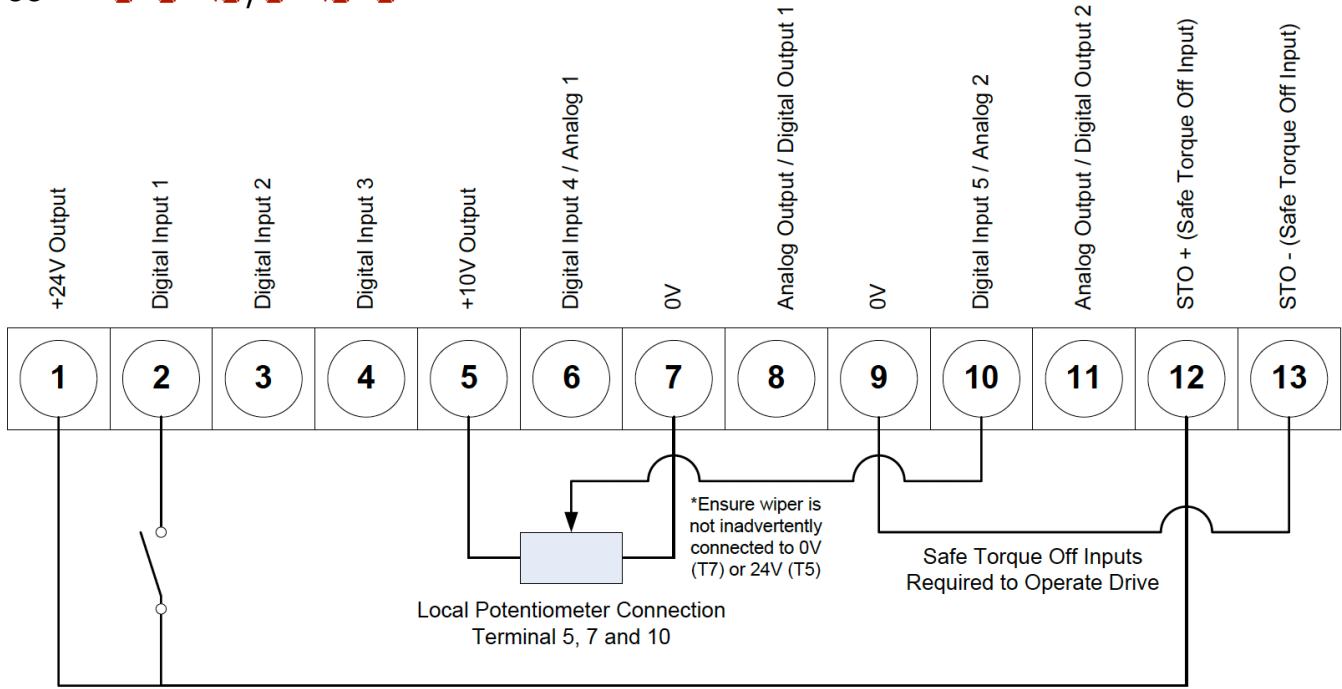

Example 2: Remote Signal Reference (voltage Source).

P2-33 = **U 0-10, U 10-0** (Matched to source)

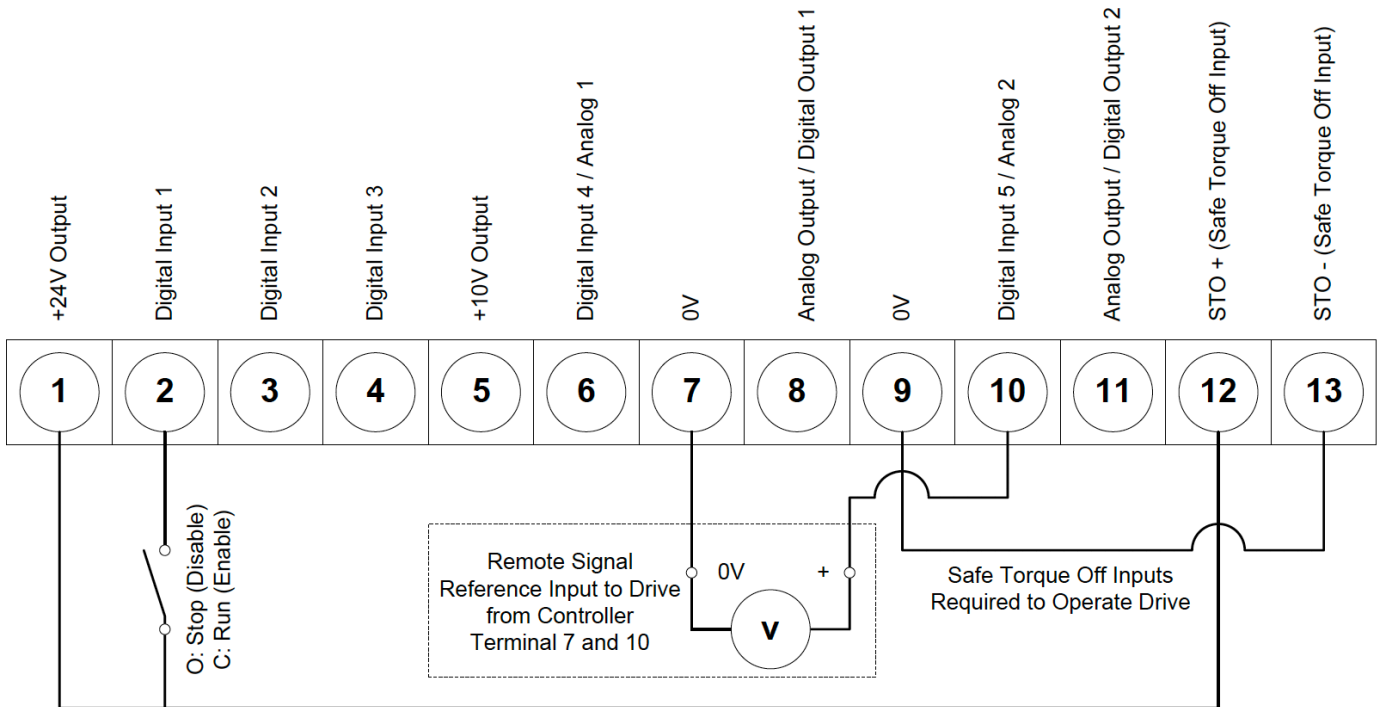

Example 3: Remote Signal Reference (Current Source).

P2-33 = *A 0-20, t 4-20, r 4-20, t 20-4, r 20-4* (Matched to source)

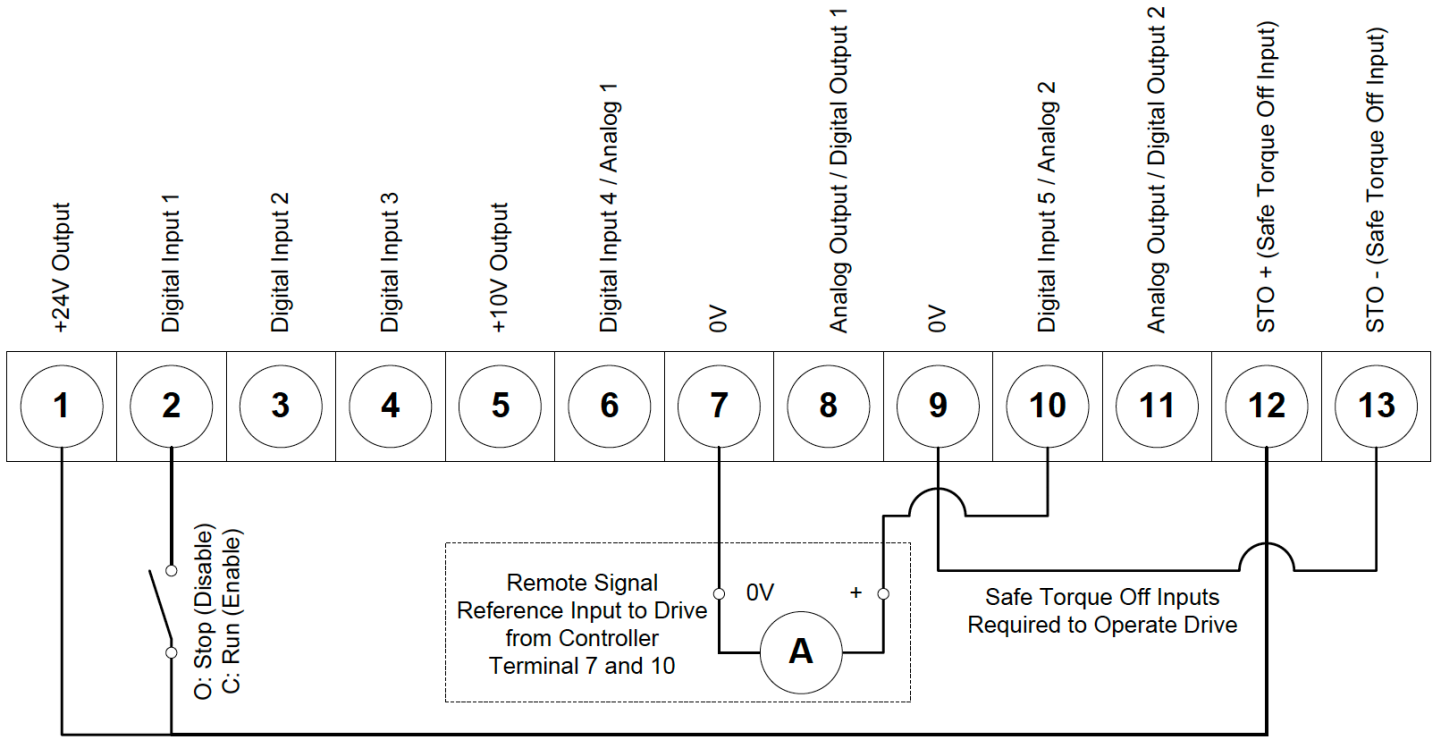

Example 4: Remote Signal Reference (Motor Thermistor).

P2-33 = *Ptc-th*

Compatible Thermistor : PTC Type, 2.5kΩ trip level

Use a setting of P1-13 that have Input 5 function as External Trip, e.g. P1-13 = 6

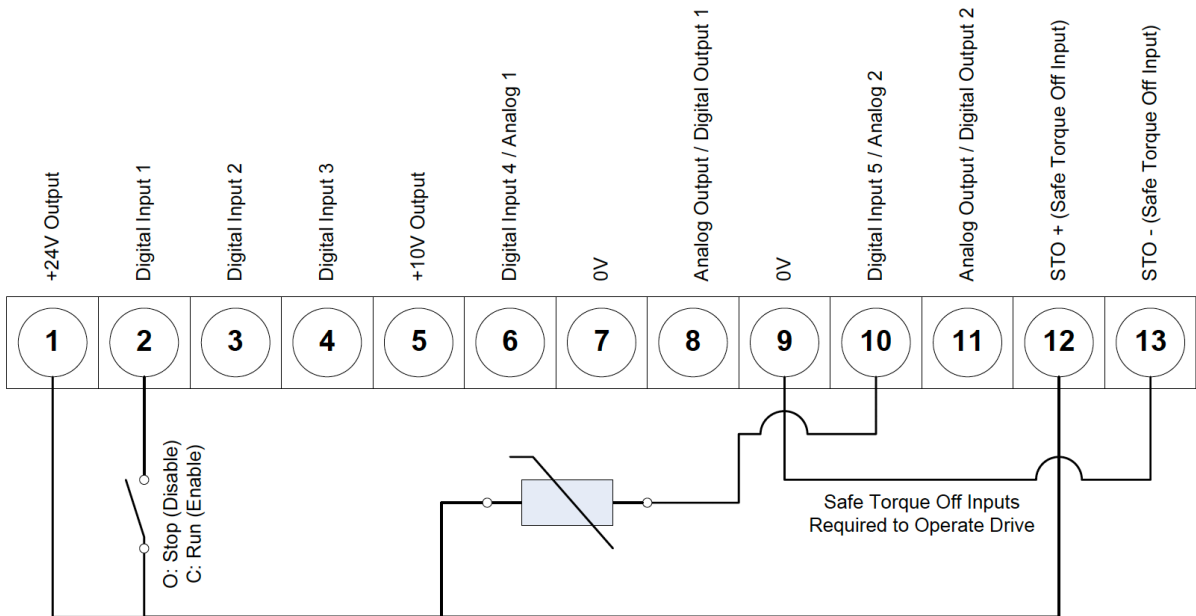

P2-31: Analog Input 1 (Terminal 6) Scaling**P2-34: Analog Input 2 (Terminal 10) Scaling**

This parameter is used to scale the analog input prior to being applied as a reference to the drive. For example, if P2-30 is set for 0 – 10V, and the scaling factor is set to 200.0%, a 5 volt input will result in the drive running at maximum speed.

P2-32: Analog Input 1 (Terminal 6) Offset**P2-35: Analog Input 2 (Terminal 10) Offset**

This parameter defines an offset for the analog input, as a percentage of the full range of the input. A positive offset is deducted from the incoming analog signal and a negative offset is added to the signal.

For example, if P2-30 is set for 0 – 10V, and the analog offset is set to 10.0%, then 1 volt (10% of 10V) will be deducted from the incoming analog reference prior to it being applied within the drive.

Appendix:

Revision History			
Version	Comments	Author	Date
1	Document Creation	JP	02/09/12
2	Revised to new format	KB	06/15/15

This application note was originally created by Invertek Drives Limited. Bardac Corporation does not claim responsibility for its contents. By using this application note, you accept that Bardac Corporation has no liability for any damage or claims resulting from the use of the information contained herein.