



40 Log Canoe Circle, Stevensville, MD 21666
 (410) 604-3400 | bardac.com | driveweb.com

APPLICATION NOTE

Drive Applications Support Library

Title	Hoist Applications
Related Products	P2 Series AC Drives
Level: 4	<ul style="list-style-type: none"> 1 - Fundamental - No previous experience necessary. 2 - Basic - Some basic drives knowledge recommended. 3 - Advanced - Some basic drives knowledge required. 4 - Expert - Good experience in topic of subject matter recommended.

Important Safety Notice:

All Bardac application notes are intended to provide general guidance concerning the use of drives in relevant applications. The information and diagrams contained within are for guidance purposes only, and do not claim to be complete, nor specifically relate to any customer applications. It is the responsibility of the system designer, installer and commissioning engineer to ensure that the drive operates in a safe manner throughout all operating conditions. By using this Application Note, you accept that Bardac Corporation has no liability for any damage or claims resulting from the use of the information contained herein.

All application notes are subject to continuous updates, and can be changed at any time without prior notice.

Bardac drives should not be used to perform any safety function beyond which they are certified for.

Overview:

For applications such as hoists, where a high starting or holding torque must be available as soon as the drive is enabled (for example to support a weight), it is necessary to pre-magnetize the motor prior to releasing the mechanical brake. Additionally, the electrical frequency must be increased from zero prior to provide a holding torque to prevent the load from dropping.

P2 series drives provide a dedicated Hoist Mode function to support these types of applications. This document describes how to enable the hoist function, and the parameters which can be adjusted to optimize its operation.

Hoist Specific Application Requirements:

Hoist applications should be handled with care, and careful attention to the system design and operation. It is essential when using drives in hoist applications to consider the following points as a minimum:

Drive Selection

It is of utmost importance to ensure that the drive operates at all times within its designed capacity to ensure safe operation in hoist applications. In many cases, hoist motors are selected based on intermittent duty, therefore the motor may frequently operate for short periods above the rated nameplate current or power capacity. For this reason, it is always advisable to select a drive power rating at least one rating higher than the motor rated power, e.g. for a 37kW / 50HP motor, the drive should be at least 45kW / 60HP.

In cases where the application has extremely high peak load demands, or is extremely critical or safety critical, it is advisable to select a drive two ratings above the motor size, e.g. for a 37kW / 50HP motor, select a 55kW / 75HP drive. This ensures that the drive is never the limiting factor in the system.

Brake Resistor Selection

All hoist applications must have a brake resistor connected to the drive. The brake resistor must be selected to suit the application, which means it must be capable of dissipating the energy required to continuously operate the hoist at maximum designed load throughout the full range of movement.

As a general guide, the brake resistor can be selected based on the motor power, and a 50% duty cycle, e.g. for a 37kW / 50HP motor, a brake resistor capable of 37kW at 50% duty should be used.

The resistance should be selected based on the minimum resistance level permissible for the drive, which is shown for each model in the User Guide.

Whenever a load is lowered, the brake resistor may be active throughout the lowering; hence the brake resistor must also be capable of dissipating the rated power for the time period involved.

The Brake Resistor should be connected to the terminals labelled "+" and "BR" on the drive.

Hoist Mode Operation:

When operating in hoist mode, the motor holding brake is controlled directly from Relay Output 2. In order to ensure the safest possible operation, when operating hoist mode the drive assumes a predefined operating status, which results in the following parameter settings effectively being ignored by the drive, and safe operating values assumed as follows:

- P1-06 : Energy Optimizer is disabled
- P2-09 & P2-10 : Skip frequencies are disabled
- P2-26 : Spin Start is disabled
- P2-27 : Standby Mode disabled

- P2-36 : Start Mode is always edge triggered
- P2-38 : Mains Loss results in a coast stop
- P4-06 & P4-07 : Torque limit is fixed at maximum available torque
- P4-08 : Minimum torque limitation set to zero
- P4-09 : Maximum regenerative torque fixed at maximum permissible limit

Important - Motor Rotation Direction:

When operating in Hoist Mode, the motor must be connected to the drive so that when the drive receives a Run Forward command, the hoist travels in the upward direction. If necessary, the output phase connection sequence to the motor can be changed to ensure the correct direction of rotation.

General Commissioning Guidelines:

It is important that the drive is correctly commissioned in a hoist application to ensure safe operation. The following guidelines are intended to highlight some of the parameters that should be checked and adjusted during the commissioning process. The list is not intended to be exhaustive for all applications, but should provide a starting point for most purposes.

- Minimum and maximum operating speeds should maintain the hoist and motor within a safe operating band. Operation at very low speeds or attempting to hold the load at zero speed without the motor brake applied is not recommended.
- Over speeding motors to provide faster operation is not recommended. When a motor operates above it's rated speed, torque is reduced, which may result in dangerous or unsafe operation.
- Acceleration times in general should be set to a high enough value to ensure reliable smooth operation and allow sufficient operator control. In general, values in the 5 – 10 second range will generally produce good results. Extremely short acceleration times will increase the stress on mechanical components, and may also make the hoist difficult to control.
- Deceleration times should be short enough to allow responsive control without excessive strain on any system components.

Hoist Mode Parameters:

In order to access the parameters required for Hoist Mode, Advanced Parameter access is required, which is enabled by setting P1-14 = P6-30 (Factory Value = 201).

Hoist Mode is enabled by setting P2-18 = 8. This enables the hoist brake control algorithm that is used whenever the drive is enabled or disabled.

Par.	Name	Min.	Max.	Default	Units
P2-07	Preset Speed 7: Brake Release Speed	0.0	P1-01	0.0	Hz / RPM
	<p>When Hoist Mode is active, this parameter defines the frequency or speed which will be used to generate a holding torque prior to releasing the mechanical brake.</p> <p>If P1-10 > 0, the value entered / displayed is in RPM.</p> <p>This parameter <u>must</u> be set > 0 when using Hoist Mode, and the value should be high enough to ensure the connected motor can develop sufficient torque to hold the maximum load capacity. In general, the value of the slip frequency or speed of the motor can be used as an initial starting setting, and adjustments made from there as necessary.</p> <p>E.g. for a 4 pole motor with a nameplate speed of 1470 Rpm, the motor slip speed = synchronous speed – rated speed = 30RPM or 1Hz.</p>				
P2-08	Preset Speed 8: Brake Apply Speed	0.0	P1-01	0.0	Hz / RPM
	<p>When Hoist Mode is active, this parameter defines the frequency or speed at which the drive will signal the motor brake to close when stopping.</p> <p>If P1-10 > 0, the value entered / displayed is in RPM.</p> <p>This parameter <u>must</u> be set > 0 when using Hoist Mode, and the value should be high enough to ensure the connected motor can develop sufficient torque to hold the maximum load capacity. In general, the same speed used for the brake release will generally provide good results.</p>				
P6-13	Hoist Mode: Brake Release (Open) Time	0.0	5.0	0.2	s
	<p>Sets the time for which the drive will hold at the Brake Release Speed (set in P2-07 - Preset Speed 7) to allow the motor brake to release. The time set must be sufficient for the brake to release. A suitable time may be obtained from the brake or motor manufacturer.</p>				
P6-14	Hoist Mode: Brake Apply (Close) Time	0.0	5.0	0.0	s
	<p>Sets the time for which the drive will hold at the Brake Apply Speed (set in P2-08 - Preset Speed 8) to allow the motor brake to engage. For vertical hoist applications this value <u>must not</u> be set below the time required for the brake to engage, as specified by the brake or motor manufacturer.</p>				
P6-15	Hoist Mode: Brake Release Torque Threshold (Torque Prove)	0.0	200.0	8.0	%
	<p>Sets the torque level, as a % of the nominal motor torque, which must be generated prior to the drive Output Relay 2 closing to signal the motor holding brake to release. This is used to ensure the motor is connected and that sufficient torque has been generated to prevent the load dropping on release of the mechanical brake.</p>				
P6-16	Hoist Mode: Torque Threshold Timeout	0.0	25.0	5.0	s
	<p>This parameter sets the time for which, following a start command, the drive will attempt to apply enough torque to the motor to reach the hoist torque probe level (P6-15). Should the torque probe level not be reached within the set time the drive will trip.</p>				
P6-17	Hoist Mode: Torque Threshold Timeout	0.0	25.0	0.0	Hz / RPM
	<p>Sets the maximum time allowed for the motor to be operating at the motor/generator torque limit (P4-07/P4-09) before tripping. This parameter is enabled only for vector control operation.</p>				

Hoist Operation - Two Speed:

In typical hoist applications, it is common to use a two preset speed approach, whereby a high speed is used for large movements, and a low speed is used for final position or operations which require more careful control. The high speed will normally be the rated speed of the motor, and the low speed will typically be 10 – 20% of this value.

Operation is normally controlled using a push button pendant operator station, which will have a Raise (Up) pushbutton and a Lower (Down) Pushbutton. The pushbuttons should be two stages, with the first stage used to enable the drive and select the direction, and the second stage used to select the High Speed operation. A simplified example wiring schematic is shown below.

Example Connection Diagram Using Two Stage Push Buttons

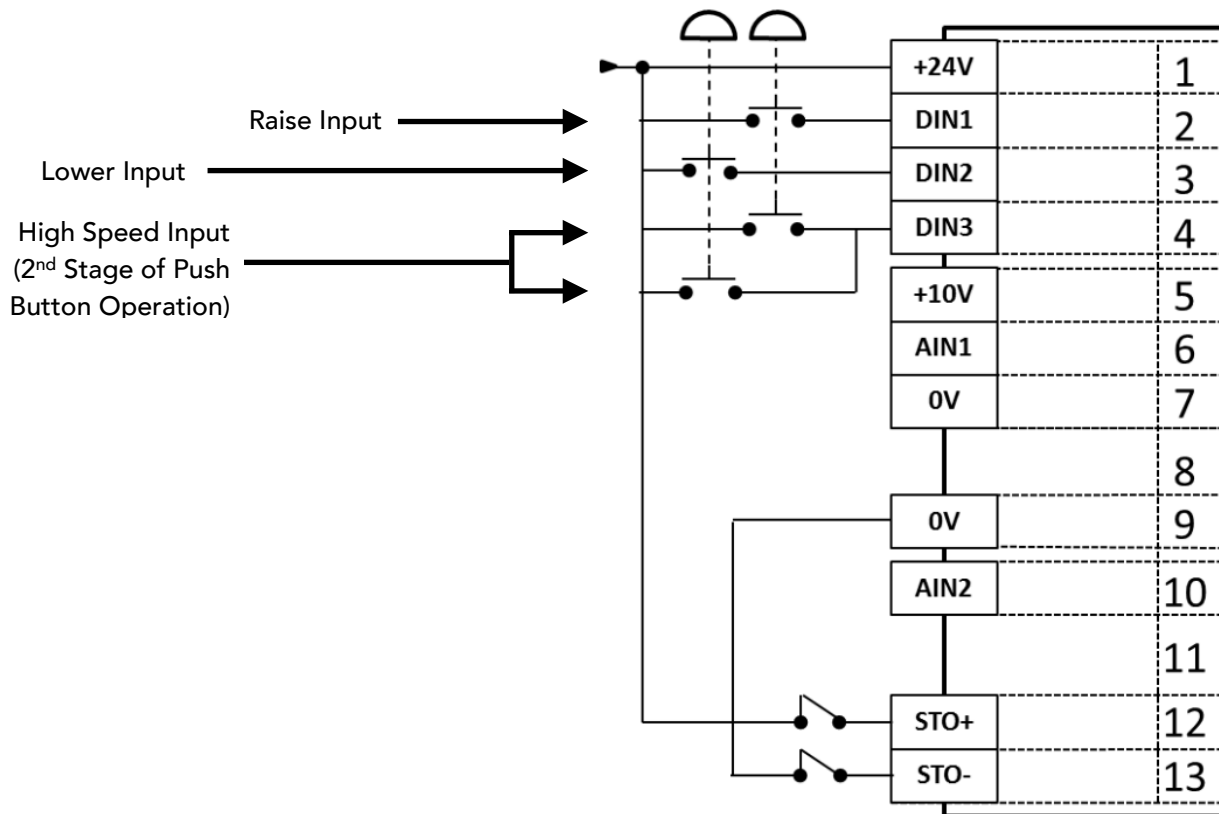

Using this example schematic, the following parameter settings are required:

Par.	Description	Setting
P1-12	Control Source Selection	0: Terminals
P1-13	Digital Inputs Function Select	12
P2-01	Low Speed	e.g. 10 Hz
P2-02	High Speed	e.g. 50 / 60 Hz

Two Speed Operation Timing Diagram:

Hoist Mode Operation

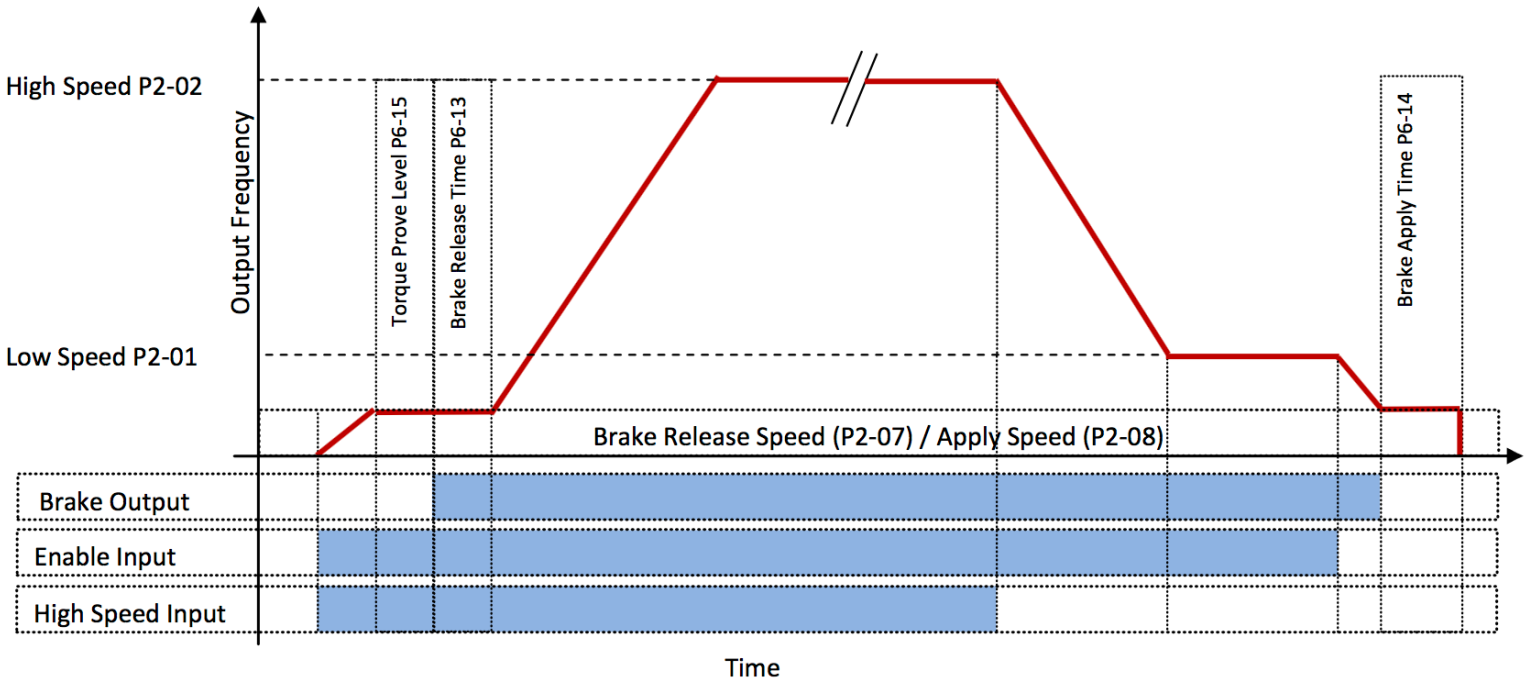

Hoist Operation - Variable Speed (Push Button):

Hoist operation is also possible with variable speed control using two stage push buttons on a pendant, sometimes referred to as "Infinitely Variable Speed Operation". In this mode, the first stage of push button operation starts the drive at minimum speed, or holds the current operating speed, while the second stage of push button operation causes the speed to increase. This allows the user to control the hoist at any speed between the minimum and maximum at any time. The connection diagram required for this is as shown below:

Example Connection Diagram Using Two Stage Push Buttons

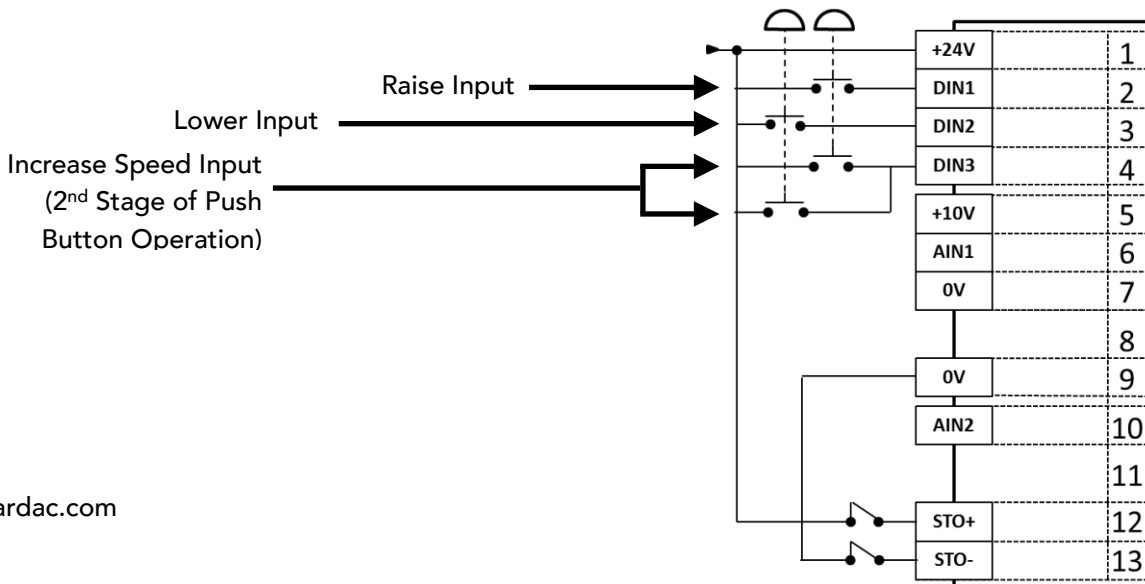

Using this example schematic, the parameter settings required are as shown below:

Par.	Description	Setting
P1-02	Minimum Operating Speed	E.g. 10 Hz
P1-12	Control Source Selection	1 : Keypad*
P1-13	Digital Inputs Function Select	20
P2-37	Keypad Mode Restart Control	6 : Current Speed

* While keypad operating mode of the drive is selected, setting P2-37 allows control to take place from the control terminals

Variable Speed Mode Example Timing Diagram:

Hoist Mode Operation

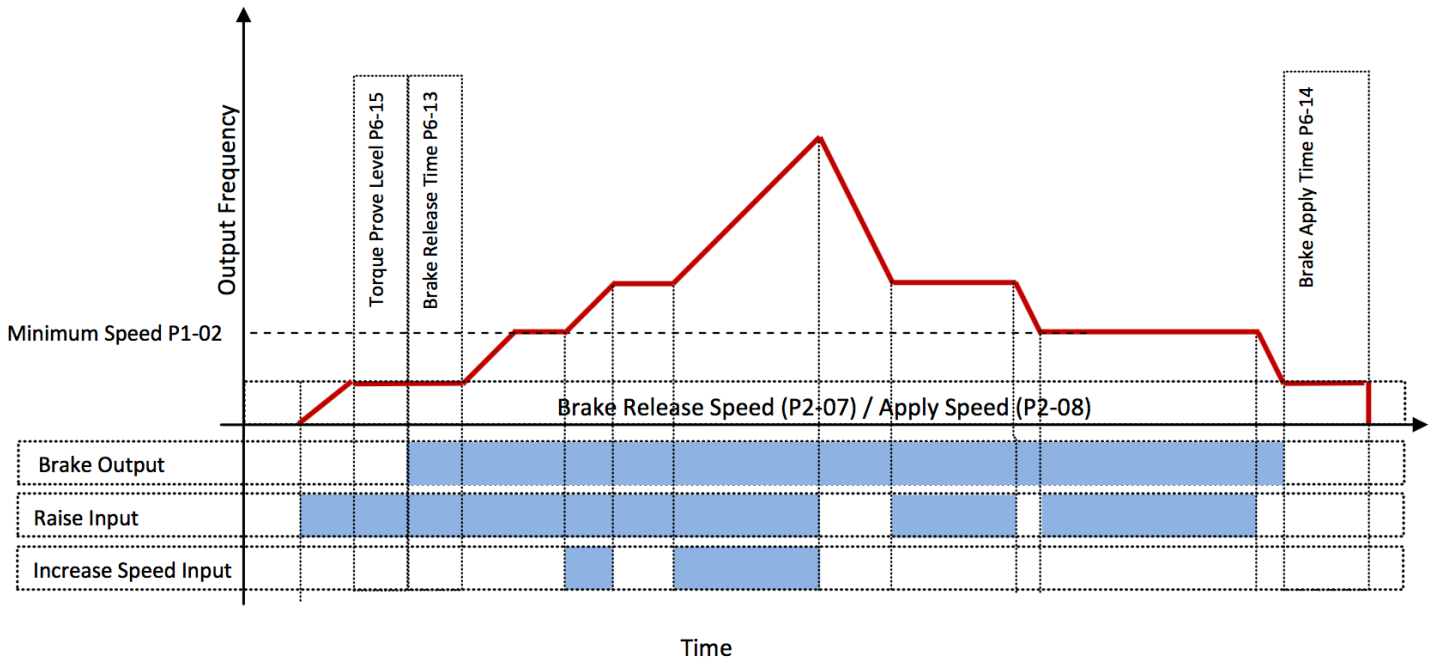

Appendix:

Revision History			
Version	Comments	Author	Date
v1.01	Additional information added, timing diagram corrected	KB (@ IDL)	10/03/2012
v1.00	Document Creation	KB (@ IDL)	04/19/2012

This application note was originally created by Invertek Drives Limited. Bardac Corporation does not claim responsibility for its contents. By using this application note, you accept that Bardac Corporation has no liability for any damage or claims resulting from the use of the information contained herein.