

# **Bardac drives** **Optidrive Plus** *3<sup>GV</sup> Technology*

## User Guide

Installation and Operating Instructions



**Bardac Corporation**  
**40 Log Canoe Circle**  
**Stevensville, MD 21666 USA**  
Phone: (410)604-3400 Fax: (410)604-3500  
[www.bardac.com](http://www.bardac.com)

Email : [info@bardac.com](mailto:info@bardac.com)

Rev. 2.10

Bardac Drives adopts a policy of continuous improvement and whilst every effort has been made to provide accurate and up to date information, the information contained in this brochure should be used for guidance purposes only and does not form the part of any contract.

**Copyright Bardac Corporation 2006**  
**Except for the purpose of supporting products sold by Bardac Drives, reproduction of all or any part of these documents is strictly prohibited.**

**Declaration of Conformity:**

Invertek Drives Ltd hereby states that the Optidrive Plus product range is CE marked for the low voltage directive and conforms to the following harmonised European directives :

- EN 50178 : Electrical equipment for use in electrical installations
- EN 61800-3 : Adjustable Speed Electrical Power Drive Systems – Part 3 (EMC)
- EN 61000-6 / -2, -3, -4 : Generic Immunity / Emissions standards (EMC)

**CE - Konformitätserklärung:**

gemäß den Produktnormen für Drehzahlveränderbare Antriebe  
Die Firma 'Invertek Drives Ltd., UK erklärt dass das Produkt: Optidrive Plus  
(statischer Frequenzumrichter zur Drehzahlregelung von Asynchronmotoren)  
nach den folgenden harmonisierten Produktnormen entwickelt und gebaut wird:

- EN 50178 : Ausrüstungen von Starkstromanlagen mit elektrischen Betriebsmitteln
- EN 61800-3 : Drehzahlveränderbare elektrische Antriebe – Teil 3 (EMV)
- EN 61000-6 / -2, -3, -4 : Elektromagnetische Verträglichkeit

**Déclaration de Conformité:**

Invertek Drives Ltd déclare par la présente que le produit Optidrive Plus porte le marquage CE en relation avec la directive basse tension et est conforme aux norms Européennes harmonisées suivantes :

- EN 50178 : Equipement électronique utilisé dans les installations de puissance
- EN 61800-3 : Entraînements électriques de puissance à vitesse variable - Partie 3
- EN 61000-6 / -2, -3, -4 : Normes génériques / Compatibilité électromagnétique (CEM)

Welshpool, 31.03.2004



Dr David Jones, R&D Director

**SIZE 6 (EXTERNAL LINE CHOKE, INTEGRAL RFI FILTER & BRAKING TRANSISTOR)**

Model	ODP-xxxx-IN	62055	62075	62090
Motor output rating – industrial 150% o/l	KW	55	75	90
Model	ODP-xxxx-USA	62075	62100	62120
Motor output rating – industrial 150% o/l	HP	75	100	120
Supply voltage / phases	V±10%	220-240 / 1Ø(with 50% derating) or 3Ø		
Supply fuse or MCB	A	315-350	400	450-500
Output voltage / phases	V	0-240 / 3Ø		
Output Amps – industrial 150% overload	A	202	240	300
Motor cable size, Copper 75 °C	mm <sup>2</sup>	90	120	170
Max motor cable length	m	100		
Min brake resistor	Ω	3		

Model	ODP-xxxx-IN	64110	64132	64160
Motor output rating – industrial 150% o/l	KW	110	132	160
Model	ODP-xxxx-USA	64160	64200	64250
Motor output rating – industrial 150% o/l	HP	160	200	250
Supply voltage / phases	V±10%	380-480 / 1Ø(with 50% derating) or 3Ø		
Supply fuse or MCB	A	315-350	400	450-500
Output voltage / phases	V	0-480 / 3Ø		
Output Amps – industrial 150% overload	A	202	240	300
Motor cable size, Copper 75 °C	mm <sup>2</sup>	90	120	170
Max motor cable length	m	100		
Min brake resistor	Ω	6		

#### SIZE 4 (INTEGRAL RFI FILTER, LINE CHOKE & BRAKING TRANSISTOR)

Model	ODP-xxxx-IN	42110	42150	42185
Motor output rating – industrial 150% o/l	KW	11	15	18.5
Model	ODP-xxxx-USA	42150	42200	42250
Motor output rating – industrial 150% o/l	HP	15	20	25
Supply voltage / phases	V±10%	220-240 / 1Ø (with 50% derating) or 3Ø		
Supply fuse or MCB	A	80-100	100	125
Output voltage / phases	V	0-240 / 3Ø		
Output Amps – industrial 150% overload	A	46	61	72
Motor cable size, Copper 75 °C	mm <sup>2</sup>	10	16	16
Max motor cable length	m	100		
Min brake resistor	Ω	6		

Model	ODP-xxxx-IN	44185	44220	44300	44370
Motor output rating – industrial 150% o/l	KW	18.5	22	30	37
Model	ODP-xxxx-USA	44250	44300	44400	44500
Motor output rating – industrial 150% o/l	HP	25	30	40	50
Supply voltage / phases	V±10%	380-480 / 1Ø (with 50% derating) or 3Ø			
Supply fuse or MCB	A	80	80-100	100	125
Output voltage / phases	V	0-480 / 3Ø			
Output Amps – industrial 150% overload	A	39	46	61	72
Motor cable size, Copper 75 °C	mm <sup>2</sup>	10	10	16	16
Max motor cable length	m	100			
Min brake resistor	Ω	12			

#### SIZE 5 (INTEGRAL RFI FILTER, LINE CHOKE & BRAKING TRANSISTOR)

Model	ODP-xxxx-IN	52220	52300	52370	52450
Motor output rating – industrial 150% o/l	KW	22	30	37	45
Model	ODP-xxxx-USA	52300	52400	52500	52600
Motor output rating – industrial 150% o/l	HP	30	40	50	60
Supply voltage / phases	V±10%	220-240 / 1Ø (with 50% derating) or 3Ø			
Supply fuse or MCB	A	160	200	250-300	250-300
Output voltage / phases	V	0-240 / 3Ø			
Output Amps – industrial 150% overload	A	89	110	150	180
Motor cable size, Copper 75 °C	mm <sup>2</sup>	25	35	55	70
Max motor cable length	m	100			
Min brake resistor	Ω	3			

Model	ODP-xxxx-IN	54450	54550	54750	54900
Motor output rating – industrial 150% o/l	KW	45	55	75	90
Model	ODP-xxxx-USA	54600	54750	54100	54150
Motor output rating – industrial 150% o/l	HP	60	75	100	150
Supply voltage / phases	V±10%	380-480 / 1Ø (with 50% derating) or 3Ø			
Supply fuse or MCB	A	160	200	250-300	250-300
Output voltage / phases	V	0-480 / 3Ø			
Output Amps – industrial 150% overload	A	90	110	150	180
Motor cable size, Copper 75 °C	mm <sup>2</sup>	25	35	55	70
Max motor cable length	m	100			
Min brake resistor	Ω	6			

#### CONTENTS

	Page
<b>1. General</b>	<b>4</b>
1.1 <i>Important safety information</i>	4
1.2 <i>Electromagnetic Compatibility (EMC)</i>	4
<b>2. Mechanical Installation</b>	<b>5</b>
2.1 <i>General</i>	5
2.2 <i>Mechanical dimensions and mounting</i>	5
2.3 <i>Enclosure mounting</i>	6
<b>3. Electrical Installation</b>	<b>7</b>
3.1 <i>Safety</i>	7
3.2 <i>Precautions</i>	7
3.3 <i>Drive and motor connection</i>	8
3.4 <i>Control terminal connections</i>	9
<b>4. Operation</b>	<b>10</b>
4.1 <i>Managing the keypad</i>	10
4.2 <i>Easy startup</i>	10
<b>5. Configuration</b>	<b>11</b>
5.1 <i>Basic parameters</i>	11
5.2 <i>Extended parameters</i>	12
5.3 <i>User Feedback control</i>	15
5.4 <i>High performance Motor control</i>	15
5.5 <i>Digital input configuration – terminal mode</i>	16
5.6 <i>Digital input configuration – keypad mode</i>	17
5.7 <i>Digital input configuration – User PID mode</i>	17
5.8 <i>Digital input configuration – Modbus control mode (Optional)</i>	18
5.9 <i>Real-time monitoring parameters</i>	18
<b>6. Troubleshooting</b>	<b>19</b>
6.1 <i>Fault finding chart</i>	19
6.2 <i>Fault messages</i>	19
6.3 <i>Auto-tune trouble shooting</i>	20
<b>7. Technical data</b>	<b>20</b>
7.1 <i>User interface</i>	20
7.2 <i>Power stage protection</i>	20
7.3 <i>Environmental</i>	20
7.4 <i>Rating tables</i>	21

All rights reserved. No part of this User Guide may be reproduced or transmitted in any form or by any means, electrical or mechanical including photocopying, recording or by any information storage or retrieval system without permission in writing from the publisher.

Copyright Invertek Drives Ltd ©2004

The manufacturer accepts no liability for any consequences resulting from inappropriate, negligent or incorrect installation, or adjustment of the optional operating parameters of the drive or from mismatching of the drive to the motor.

The contents of this User Guide are believed to be correct at the time of printing. In the interest of a commitment to a policy of continuous improvement, the manufacturer reserves the right to change the specification of the product or its performance or the contents of the User Guide without notice.

All Invertek drives products carry a 2-year warranty, valid from the date of manufacture. This data is clearly visible on the rating label.

## 1. General

### 1.1 Important safety information



This variable speed drive product (Optidrive) is intended for professional incorporation into complete equipment or systems. If installed incorrectly it may present a safety hazard. The Optidrive uses high voltages and currents, carries a high level of stored electrical energy, and is used to control mechanical plant that may cause injury. Close attention is required to system design and electrical installation to avoid hazards in either normal operation or in the event of equipment malfunction.

System design, installation, commissioning and maintenance must be carried out only by personnel who have the necessary training and experience. They must carefully read this safety information and the instructions in this Guide and follow all information regarding transport, storage, installation and use of the Optidrive, including the specified environmental limitations.

**Please read the IMPORTANT SAFETY INFORMATION below, and all Warning and Caution information elsewhere.**

### Safety of machinery, and safety-critical applications



The level of integrity offered by the Optidrive control functions – for example stop/start, forward/reverse and maximum speed, is not sufficient for use in safety-critical applications without independent channels of protection. All applications where malfunction could cause injury or loss of life must be subject to a risk assessment and further protection provided where needed. Within the European Union, all machinery in which this product is used must comply with Directive 89/392/EEC, Safety of Machinery. In particular, the electrical equipment should comply with EN60204-1.

### 1.2 Electromagnetic compatibility (EMC)

Optidrive is designed to high standards of EMC. EMC data is provided in a separate EMC Data Sheet, available on request. Under extreme conditions, the product might cause or suffer disturbance due to electromagnetic interaction with other equipment. It is the responsibility of the installer to ensure that the equipment or system into which the product is incorporated complies with the EMC legislation of the country of use. Within the European Union, equipment into which this product is incorporated must comply with 89/336/EEC, Electromagnetic Compatibility.

When installed as recommended in this User Guide, the radiated emissions levels of all Optidrives are less than those defined in the Generic radiated emissions standard EN61000-6-4. Every Optidrive has a built-in filter to reduce conducted emissions. The conducted emission levels are less than those defined in the Generic radiated emissions standard EN61000-6-4 (class A) for the following cable lengths :

Optidrive sizes #1 to #3 : up to 5m of screened cable  
Optidrive sizes #4 to #6 : up to 25m of screened cable

Optidrive sizes #1 to #3 can be fitted with an optional external Optifiter (HF filter). When correctly fitted with this filter, the conducted emission levels are less than those defined in the Generic radiated emissions standard EN61000-6-3 (class B) for screened cable lengths up to 5m and with EN61000-6-4 (class A) for screened cable lengths up to 25m.

## 7.4 Drive rating tables

### SIZE 1 (INTEGRAL RFI FILTER)

Model	ODP-xxxxx-IN	12037	12075
Motor output rating – industrial 150% o/l	KW	0.37	0.75
Model	ODP-xxxxx-USA	12005	12010
Motor output rating – industrial 150% o/l	HP	0.5	1.0
Supply voltage / phases	V±10%	220-240 / 1Ø	
Supply fuse or MCB	A	6	10
Output voltage / phases	V	0-240V / 3Ø	
Output Amps – industrial 150% overload	A	2.3	4.3
Motor cable size, Copper 75 °C	mm <sup>2</sup>	1.0	
Max motor cable length	m	25	

### SIZE 2 (INTEGRAL RFI FILTER, INTEGRAL BRAKING TRANSISTOR)

Model	ODP-xxxxx-IN	22150	22220
Motor output rating – industrial 150% o/l	KW	1.5	2.2
Model	ODP-xxxxx-USA	22020	22030
Motor output rating – industrial 150% o/l	HP	2	3
Supply voltage / phases	V±10%	220-240 / 1Ø	
Supply fuse or MCB	A	20	30
Output voltage / phases	V	0-240V / 3Ø	
Output Amps – industrial 150% overload	A	7	10.5 (* 9)
Motor cable size, Copper 75 °C	mm <sup>2</sup>	1.5	
Max motor cable length	m	100	
Min brake resistor	Ω	33	22

Model	ODP-xxxxx-IN	24075	24150	24220	24400
Motor output rating – industrial 150% o/l	KW	0.75	1.5	2.2	4.0
Model	ODP-xxxxx-USA	24010	24020	24030	24050
Motor output rating – industrial 150% o/l	HP	1	2	3	5
Supply voltage / phases	V±10%	380-480 / 3Ø			
Supply fuse or MCB	A	6 - 10	10	10	20
Output voltage / phases	V	0-480 / 3Ø			
Output Amps – industrial 150% overload	A	2.2	4.1	5.8	9.5
Motor cable size, Copper 75 °C	mm <sup>2</sup>	1.0		1.5	
Max motor cable length	m	50	100	100	100
Min brake resistor	Ω	47	47	47	33

### SIZE 3 (INTEGRAL RFI FILTER, INTEGRAL DC LINK CHOKE & BRAKING TRANSISTOR)

Model	ODP-xxxxx-IN	32030	32040	32055	32075
Motor output rating – industrial 150% o/l	KW	3.0	4.0	5.5	7.5
Model	ODP-xxxxx-USA	32040	32050	32075	32100
Motor output rating – industrial 150% o/l	HP	4	5.5	7.5	10
Supply voltage / phases	V±10%	220-240 / 1Ø(with 50% derating) or 3Ø			
Supply fuse or MCB	A	32	32	50	50
Output voltage / phases	V	0-240 / 3Ø			
Output Amps – industrial 150% overload	A	14	18	25 (* 24)	30 **
Motor cable size, Copper 75 °C	mm <sup>2</sup>	2.5	2.5	4	4
Max motor cable length	m	100			
Min brake resistor	Ω	15			

Model	ODP-xxxxx-IN	34055	34075	34110	34150
Motor output rating – industrial 150% o/l	KW	5.5	7.5	11.0	15.0
Model	ODP-xxxxx-USA	34075	34100	34150	34200
Motor output rating – industrial 150% o/l	HP	7.5	10	15	20
Supply voltage / phases	V±10%	380-480 / 1Ø(with 50% derating) or 3Ø			
Supply fuse or MCB	A	32	32	50	50
Output voltage / phases	V	0-480 / 3Ø			
Output Amps – industrial 150% overload	A	14	18	25 (* 24)	30 **
Motor cable size, Copper 75 °C	mm <sup>2</sup>	2.5	2.5	4	6
Max motor cable length	m	100			
Min brake resistor	Ω	22			

\* Maximum rating for UL applications

\*\* Models not UL listed

### 6.3 Auto-tune trouble shooting

Trip message	Explanation and check point
At-F01	Measured motor stator resistance varies between phases. Ensure that all motor phases are connected to the drive. Check motor for winding imbalance.
At-F02	Measured motor stator resistance is too large. Ensure that motor is connected. Check that the motor power matches the drive power rating.
At-F03	Measured motor inductance is too low. Ensure that there is no short circuit on the motor or a winding fault. Check that the motor power matches drive power rating.
At-F04	Measured motor inductance is too high. Check for motor connection fault. Check that the motor power matches drive power rating.
At-F05...At-F07	Motor parameter measurements not convergent. Check motor windings for fault. Check that the motor power matches drive power rating.

Notes: Ensure that the correct motor nameplate parameters are entered in P1-07...P1-09 before the Auto-tune is carried out. Ensure that the motor winding (star or delta) connection is correct and that the motor is connected to the drive.

## 7. Technical data

### 7.1 User interface

Bipolar Analog Input : (terminal 6)	Resolution = +/-12-bits (0.025%), 8ms sampling time Range settings: 0..10V, 0..24V, -10..10V. Max input voltage 30V DC
2 <sup>nd</sup> Analog input : (terminal 4)	Resolution = +11-bits (0.05%), 8ms sampling time Range settings: 0..10V, 4..20mA, 0..20mA. Max input voltage 30V DC
Digital inputs : (terminals 2, 3, 4)	Positive logic only. Sampling interval : 8ms sampling time "Logic 1" input voltage range: 8V ... 30V DC. "Logic 0" input voltage range: 0 ... 4V DC.
User +24V output : (terminals 1, 5)	Output regulation +/-2.5% over full load range. Max output current = 100mA total. Short circuit proof.
Analog output : (terminal 8)	Resolution = 8-bits, 16ms update cycle time Output formats: 0...10V, 4...20mA. Max current = 20mA. Short circuit proof.
2 <sup>nd</sup> digital output : (terminal 3)	PNP output, max output current = 10mA. Short circuit proof.
User relay : (terminals 10, 11)	Contact rating : 250Vac, 6A / 30Vdc, 5A.

### 7.2 Power stage protection

- Output short-circuit, phase-to-phase, phase-to-earth.
- Output over-current. Trip set at 200% of RMS rated drive current.
- Overload protection. Drive delivers 150% of rated motor current for 60s.
- Braking transistor protected against short-circuit.
- Braking resistor overload. (when enabled)
- Over-voltage trip. Set at 123% of drive maximum rated supply voltage.
- Under-voltage trip.
- Over temperature trip.
- Under temperature trip. (Drive will trip if enabled below 0 °C)
- Supply Phase imbalance. A supply imbalance of >3% persisting for more than 30s will trip a running drive.
- Supply Phase loss. If one phase of a 3-phase supply is lost for more than 15s, a running drive will trip.

### 7.3 Environmental

Operational temperature range : 0 ... 50 °C  
Storage temperature range : -40 ... 60 °C  
Maximum altitude : 2000m. Derate above 1000m : 1% / 100m  
Maximum humidity : 95%, non-condensing

## 2. Mechanical Installation

### 2.1 General

- Carefully inspect the Optidrive before installation to ensure it is undamaged
- Store the Optidrive in its box until required. Storage should be clean and dry and within the temperature range -40°C to +60°C
- Install the Optidrive on a flat, vertical, flame-resistant, vibration-free mounting within a suitable enclosure, according to EN60529 if specific Ingress Protection ratings are required
- Flammable material should not be placed close to the drive
- The entry of conductive or flammable foreign bodies should be prevented
- Max. operational ambient temperature 50°C, min. 0°C. Refer to rating tables in section 7.4
- Relative humidity must be less than 95% (non-condensing)
- Optidrives can be installed side-by-side with their heatsink flanges touching. This gives adequate ventilation space between them. If the Optidrive is to be installed above another drive or any other heat-producing device, the minimum vertical spacing is 150mm. The enclosure should either be force-ventilated or large enough to allow natural cooling (allow 0.1 m<sup>3</sup> per kW of drive rating).

### 2.2 Mechanical dimensions and mounting

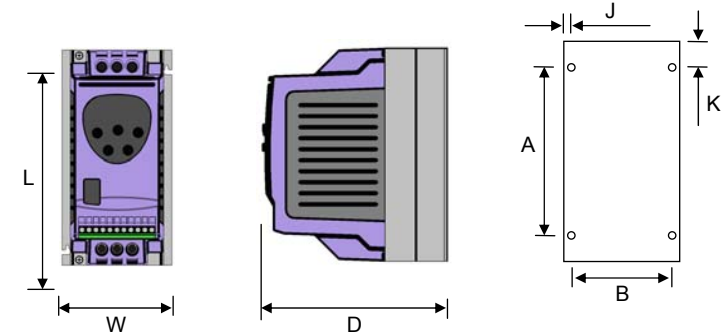

	Size 1	Size 2	Size 3	Size 4	Size 5 (#1) *	Size 5 (#2) *	Size 6
Length / mm	155	260	260	520	1045	1100	1100
Width / mm	80	100	171	340	340	340	340
Depth / mm	130	175	175	220	220	330	330
Weight/ kg	1.1	2.6	5.3	28	67	68	55 **
A / mm	105	210	210	420	945	945	945
B / mm	72	92	163	332	332	332	332
J / mm	4				9.5		
K / mm	25				50		
Fixings	2 * M4		4 * M4		4 * M8		
Power Terminal torque settings	1 Nm			4 Nm	8 Nm		

\* Size 5 (#1) – 90A and 110A ratings

\* Size 5 (#2) – 150A and 180A ratings

\*\* S6 has external line choke, weight 27kg

### 2.3 Enclosure mounting and dimensions

For applications that require a higher IP rating than the IP20 offered by the standard drive, the drive must be mounted in an enclosure. The following guidelines should be observed for these applications:

- Enclosures should be made from a thermally conductive material, unless forced ventilation is used.
- When vented enclosures are used, there should be venting above the drive and below the drive to ensure good air circulation. Air should be drawn in below the drive and expelled above the drive.
- If the external environment contains contamination particles (eg dust), a suitable particle filter should be fitted to the vents and forced ventilation implemented. The filter must be serviced / cleaned appropriately.
- High moisture, salt or chemical content environments should use a suitably sealed (non-vented) enclosure.

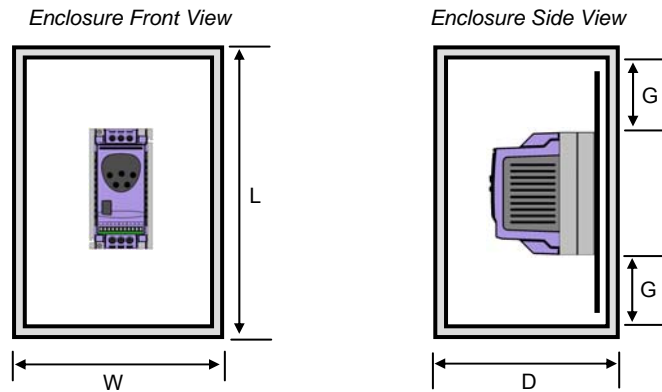

Non-Vented Enclosure Dimensions (mm)

Drive Power rating	L	W	D	G
Size 1 0.75kW 230V	300	250	200	50
Size 1 1.5kW 230V	400	300	250	75
Size 2 1.5kW 230V / 2.2kW 400V	400	300	300	60
Size 2 2.2kW 230V / 4kW 400V	600	450	300	100

Vented Enclosure Dimensions (mm)

Drive Power rating	Free-Vented unit				Force-vented unit				Air Flow
	L	W	D	G	L	W	D	G	
Size 1 1.5 kW	400	300	150	75	300	200	150	75	> 15m <sup>3</sup> /h
Size 2 4 kW	600	400	250	100	400	300	250	100	> 45m <sup>3</sup> /h
Size 3 15 kW	800	600	300	150	600	400	250	150	> 80m <sup>3</sup> /h
Size 4 22 kW	1000	600	300	200	800	600	300	200	> 300m <sup>3</sup> /h
Size 4 37 kW	-	-	-	-	800	600	300	200	> 300m <sup>3</sup> /h
Size 5 90 kW	-	-	-	-	1600	800	400	200	> 900m <sup>3</sup> /h
Size 6 160 kW	-	-	-	-	2000	800	400	200	>1000m <sup>3</sup> /h

## 6. Troubleshooting

### 6.1 Fault-finding chart

Symptom	Cause and Solution
Overload or over-current trip on unloaded motor during acceleration	Check Star / Delta terminal connection in motor. Rated operating voltage of drive and motor should match. The Delta connection always gives the lower voltage rating of a dual voltage motor
Overload or over-current – motor does not spin	Check for locked rotor. Check that the mechanical brake is released (if fitted)
Drive will not enable – display remains on 'StoP'	Check that the hardware enable signal is applied to digital input 1. Ensure that the User +24V output voltage (between terminals 5 and 7) is correct. If not, check wiring to user terminal strip. Check P1-12 for terminal / keypad mode. If keypad mode selected, press the START button. Check that supply voltage is within specification.
Drive runs incorrectly when in vector mode	Ensure that the motor name plate data has been entered into P1-07, P1-08, P1-09 before the parameter auto-tune function has been carried out. Set P4-02 = 1 to carry out auto-tune.
In very cold ambient conditions, drive will not power up	If the ambient temperature is less than -10 °C, the drive may not power up. Ensure that a local heating source keeps the ambient above 0 °C in these conditions.
Speed limit or rated frequency parameters cannot be set above 250Hz, 500Hz or 1000Hz	The maximum output motor frequency is limited by the switching frequency. Ensure that P2-24 is at least 16x greater than the required motor output frequency before setting the required maximum or rated output frequency parameters.
Extended menus cannot be accessed	Ensure that P1-14 is set to the extended access code. This is "101" unless the code in P2-37 has been changed by the user.

### 6.2 Fault messages

Trip message	Explanation
P-dEF	Default parameters loaded, usually after pressing STOP, UP & DOWN keys for 1s. Press STOP to reset the trip. Display then reads "StoP"
"O-I"	Over-current on drive output to motor. Trip on drive enable : check for wiring error or short circuit Trip on motor starting : check for stalled or jammed motor Trip during operation : check for sudden overload or malfunction
"l.t-trP"	Drive overload trip, occurring when the drive has been delivering >100% rated current (set in P1-08) for a period of time. The display flashes to indicate an overload condition.
"O-Uolt"	Over-voltage on DC bus. Check supply voltage is within limits. If trip occurs on deceleration, increase deceleration time or fit braking resistor.
"U-Uolt"	Under-voltage trip. Happens routinely when drive powered down. If it occurs whilst running, check supply voltage
"OI-b"	Over current in the brake resistor circuit. Check cabling to brake resistor
"OL-br"	Brake resistor overload. Increase deceleration time, reduce load inertia or add further brake resistors in parallel. Ensure minimum resistance values from ratings tables in section 7.4 are observed.
"O-t"	Over-temperature trip. Check drive cooling and possible enclosure dimensions
"U-t"	Under-temperature trip. Trip occurs if ambient is less than 0°C. Drive ambient temperature must be raised above zero in order to start the drive.
"PS-trP"	Trip on drive enable : check for wiring error or short circuit Trip during operation : check for sudden overload or over-temperature
"dAtA-F"	Occurs routinely after Flash upgrade. Reset using the STOP button or after a power down cycle. All parameters set to default after an upgrade.
"P-LOSS"	If a drive intended for use with a 3-phase supply has one phase removed. Condition must persist for >15s before a trip occurs. Phase loss detection disabled if parameters defaulted (P-dEF) when L3 has been removed.
"Ph-ib"	Phase imbalance. Trips if the phase imbalance exceeds 3%. Condition must persist for >30s before a trip occurs.
"SC-trP"	Check integrity of OptiLink (communication link) between drives interconnected optically. Check that each drive in a network has a unique drive address (P2-27) <i>If Modbus function enabled, check Modbus communication link.</i>
"E-trip"	External trip (connected to digital input 3). Check motor thermistor (if connected)
"At-Fxx"	Auto-tune failed to complete successfully. (xx = 01...07) See 6.3 for more details.

### 5.8 Digital input configuration – Modbus control mode (Optional – P1-12 = 4)

The following table defines the digital input functionality when the drive is in Modbus control mode.

P2-01	Digi input 1 function	Digi input 2 function	Digi input 3 function	Additional information	
0..2,4 6..10, 13..19	O : Stop (Disable) C : Run (Enable)	No effect	No effect	Digital input 1 must be closed to enable the drive	
3	O : Stop (Disable) C : Run (Enable)	O : Forward C : Reverse	O : Master speed ref C : Speed Preset 1		
5	O : Stop (Disable) C : Run (Enable)	O : Master speed ref C : Preset speed	Digi input 3	Analog input	Preset value
			Open	Open	Preset speed 1
			Closed	Open	Preset speed 2
			Open	Closed	Preset speed 3
			Closed	Closed	Preset speed 4
11	O : Stop (Disable) C : Run (Enable)	O : Master speed ref C : Speed Preset 1	External trip input : O : trip C : OK	Digital input 1 must be closed to enable the drive	
12	O : Stop (Disable) C : Run (Enable)	O : Speed Preset 1 C : Master speed ref	External trip input : O : trip C : OK		
19	O : Stop (Disable) C : Run (Enable)	O : Master speed ref C : Analog input 1	No effect		
20,21	O : Stop (Disable) C : Run (Enable)	2 <sup>nd</sup> digital output : Drive healthy = +24V	O : Master speed ref C : Speed Preset 1		
22	O : Stop (Disable) C : Run (Enable)	2 <sup>nd</sup> digital output : Drive healthy = +24V	External trip input : O : trip C : OK		

**Notes:** If P1-19 = 2 or 3, drive can only be started / stopped by closing / opening digital input 1. If P1-19 = 0 or 2, the master speed reference will be automatically reset to zero each time when drive is stopped.

### 5.9 Real-time monitoring parameters

Parameter group zero provides access to internal drive read-only parameters for monitoring purposes.

Par	Description	Display range	Explanation
P0-01	Bipolar analog input value	-100%...100%	100% = max input voltage
P0-02	2 <sup>nd</sup> analog input value	0..100%	100% = max input voltage
P0-03	Speed controller reference	-500%...500%	100% = Base frequency (P1-09)
P0-04	Digital speed ref (digi pot)	- P1-01 ... P1-01	Speed displayed in Hz / rpm
P0-05	Torque controller reference	0 ...200%	100% = motor rated torque
P0-06	User PID ref input	0..100%	PID controller reference value
P0-07	User PID feedback	0..100%	PID controller feedback value
P0-08	User PID error input	0..100%	Reference – Feedback
P0-09	User PID P-term	0..100%	Proportional component
P0-10	User PID I-term	0..100%	Integral component
P0-11	User PID D-term	0..100%	Differential component
P0-12	User PID output	0..100%	Combined output
P0-13	Output Torque	0..200%	100% = motor rated torque
P0-14	Magnetising current	A rms	Magnetising current in A rms
P0-15	Rotor current	A rms	Rotor current in A rms
P0-16	Field strength	0..100%	Magnetic field strength
P0-17	Stator resistance	Ohm	Phase - Phase stator resistance
P0-18	Stator inductance	H	Stator inductance in Henry
P0-19	Rotor resistance	Ohm	Calculated rotor resistance
P0-20	DC bus voltage	V dc	Internal DC bus voltage
P0-21	Drive temperature	°C	Internal drive temperature
P0-22	Supply voltage L1 – L2	V rms, ph-ph	Phase – phase supply voltage
P0-23	Supply voltage L2 – L3	V rms, ph-ph	Phase – phase supply voltage
P0-24	Supply voltage L3 – L1	V rms, ph-ph	Phase – phase supply voltage
P0-25	Estimated Rotor speed	Hz or rpm	Applies to vector modes only
P0-26	kWh meter	0.0 ... 999.9 kWh	Cumulative energy consumption
P0-27	MWh meter	0.0 ... 60000 MWh	Cumulative energy consumption
P0-28	Software ID, IO processor	eg "1.00", "493F"	Version number and checksum
P0-29	Software ID, Motor control	eg "1.00", "7A5C"	Version number and checksum
P0-30	Drive serial number	000000 ... 999999 00-000 ... 99-999	Unique drive serial number eg 540102 / 24 / 003

## 3. Electrical Installation

### 3.1 Safety



**Electric shock hazard!** Disconnect and **ISOLATE** the Optidrive before attempting any work on it. High voltages are present at the terminals and within the drive for up to 10 minutes after disconnection of the electrical supply.

- Optidrive should be installed only by qualified electrical persons and in accordance with local and national regulations and codes of practice.
- The Optidrive has an Ingress Protection rating of IP20. For higher IP ratings, use a suitable enclosure.
- Where the electrical supply to the drive is through a plug and socket connector, do not disconnect until 10 minutes have elapsed after turning off the supply
- Ensure correct earthing connections, see diagram below
- The earth cable must be sufficient to carry the maximum supply fault current which normally will be limited by the fuses or MCB

### 3.2 Precautions

- Ensure that the supply voltage, frequency and number of phases (single or three phase) correspond to the rating of the Optidrive as delivered
- An isolator or similar should be installed between the power supply and the drive
- Never connect the mains power supply to the Optidrive output terminals UVW
- Protect the drive by using slow-blow HRC fuses or an MCB located in the mains supply to the drive
- Do not install any type of automatic switchgear between the drive and the motor
- Wherever control cabling is close to power cabling, maintain a minimum separation of 100 mm and arrange crossings at 90°
- Ensure that screening or armouring of power cables is effected in accordance with the connections diagram below
- Ensure that all terminals are tightened to the appropriate torque (see table, left)

Connect drive according to the following diagram, ensuring that motor terminal box connections are correct. There are two connections in general : Star and Delta. It is essential to ensure that the motor is connected in accordance with the voltage at which it will be operated. For more information, refer to the following diagram

For recommended cabling and wiring sizing, refer to section 7.4.

It is recommended that the power cabling should be 3-core or 4-core PVC-insulated screened cable, laid in accordance with local industrial regulations and codes of practice.

The ground terminal of each Optidrive should be individually connected DIRECTLY to the site earth (ground) bus-bar (through the filter if installed) as shown. Optidrive ground connections should not loop from one drive to another, or to, or from any other equipment. Ground loop impedance must conform to local industrial safety regulations. To meet UL regulations, UL approved ring crimp terminals should be used for all earth wiring connections.

### 3.3 Drive and motor connection

Each drive star connected to system earth point

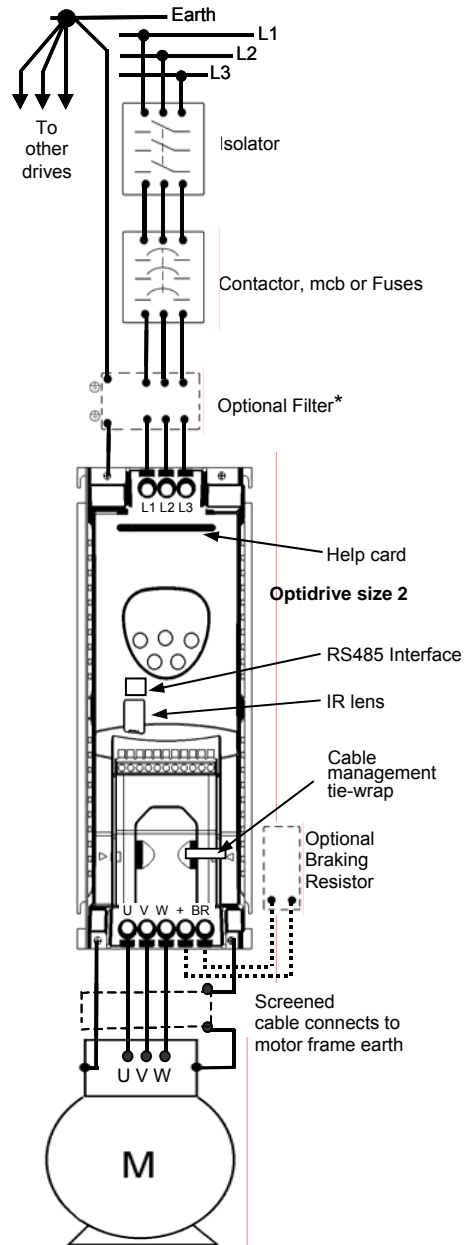

\* If fitted, a filter should be mounted physically close to the Drive. For maximum effectiveness, the metal case of the filter and the heat sink of the drive should be electrically connected, ie screw both to a metal back plate and ensure metal-to-metal contact.

#### Motor terminal box connections

Most general purpose motors are wound for operation on dual voltage supplies. This is indicated on the nameplate of the motor

This operational voltage is normally selected when installing the motor by selecting either STAR or DELTA connection.

STAR always gives the higher of the two voltage ratings.

Typical ratings are :

400 / 230 (  $\Delta$  /  $\Delta$  )

690 / 400 (  $\Delta$  /  $\Delta$  )

DELTA (  $\Delta$  ) Connection

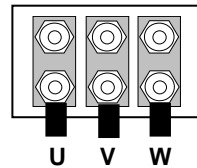

STAR (  $\Delta$  ) Connection

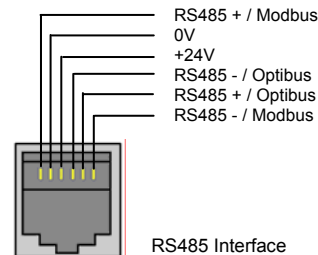
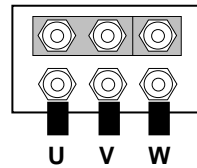

### 5.6 Digital input configuration – keypad mode (P1-12 = 1 or 2)

The following table defines the function of the digital inputs when the drive is in keypad mode

P2-01	Digi input 1 function	Digi input 2 function	Digi input 3 function	Additional information
* 0	O : Stop (Disable) C : Run (Enable)	Closed : Remote pushbutton UP	Closed : Remote pushbutton DOWN	When drive is stopped, closing digital inputs 2 & 3 together starts drive. Bipolar analog input has no effect
* 1	O : Stop (Disable) C : Run (Enable)	Closed : Remote pushbutton UP	External trip input : O : Trip C : OK	Closed : Remote pushbutton DOWN
* 2	O : Stop (Disable) C : Run (Enable)	Closed : Remote pushbutton UP	O : Digital speed ref C : Speed Preset 1	Bipolar analog input > 5V reverses rotation
* 3..10, 13,14, 16	O : Stop (Disable) C : Run (Enable)	Closed : Remote pushbutton UP	Closed : Remote pushbutton DOWN	When drive is stopped, closing digital inputs 2 & 3 together starts drive. Bipolar analog input > 5V reverses rotation
11	O : Stop (Disable) C : Run (Enable)	O : Digital speed ref C : Speed Preset 1	External trip input : O : Trip C : OK	Allows connection of motor thermistor. Bipolar analog input > 5V reverses rotation
12	O : Stop (Disable) C : Run (Enable)	O : Speed Preset 1 C : Digital speed ref	External trip input : O : Trip C : OK	Allows connection of motor thermistor. Bipolar analog input > 5V reverses rotation
15	O : Stop (Disable) C : Run (Enable)	O : Digital speed ref C : Speed Preset 1	O : Decel ramp 1 C : Decel ramp 2	Bipolar analog input > 5V reverses rotation
17,18	O : Stop (Disable) C : Run (Enable)	No effect	No effect	No effect
19	O : Stop (Disable) C : Run (Enable)	O : Digital speed ref C : Analog input 1	No effect	No effect
20,21	O : Stop (Disable) C : Run (Enable)	2 <sup>nd</sup> digital output : Drive healthy = +24V	O : Digital speed ref C : Speed Preset 1	Bipolar analog input > 5V reverses rotation
22	O : Stop (Disable) C : Run (Enable)	2 <sup>nd</sup> digital output : Drive healthy = +24V	External trip input : O : Trip C : OK	Bipolar analog input > 5V reverses rotation

#### Notes:

- In addition to the speed being set using the pushbuttons on the front of the drive, the settings designated with " \* " allow the speed to be controlled remotely using remote pushbuttons connected to digital inputs 2 and 3.
- When P2-01 = 17 or 18, keypad mode is selected from within terminal mode (see table 5.5). For this reason, the remaining digital inputs have no effect.
- When P2-19 = 2 or 3 in keypad mode, the drive START and STOP is controlled from the hardware enable input (terminal 2). In this case, the START / STOP buttons are not required and therefore have no effect.
- The remote push-button functionality via digital inputs is disabled if P2-01 = 1.
- Reverse rotation control using the analog input only works in this mode. If P1-12=1, the rotation direction control only works when P2-19 = 2 or 3.
- If P2-35 = 2 or 3, then the analog reverse function will not work, and the remote keypad function will also be disabled if P2-01 = 1.

### 5.7 Digital input configuration – User PID mode (P1-12 = 3)

The following table defines the function of the digital inputs when the drive is in User PID control mode.

P2-01	Digi input 1 function	Digi input 2 function	Digi input 3 function	Additional information
0..10, 13..18	O : Stop (Disable) C : Run (Enable)	No effect	No effect	Digital input 1 must be closed to run the drive
11	O : Stop (Disable) C : Run (Enable)	O : PID control C : Speed Preset 1	No effect	
12	O : Stop (Disable) C : Run (Enable)	O : Speed Preset 1 C : PID control	No effect	
19	O : Stop (Disable) C : Run (Enable)	O : PID control C : Bipolar analog input	No effect	
20..22	O : Stop (Disable) C : Run (Enable)	2 <sup>nd</sup> digital output : Drive healthy = +24V	No effect	



### 5.5 Digital input configuration – terminal mode (P1-12 = 0)

P2-01	Digi input 1 function	Digi input 2 function	Digi input 3 function	Analog input function	
0	O : Stop (Disable) C : Run (Enable)	O : Bipolar analog input C : Speed Preset 1, 2	O : Speed Preset 1 C : Speed Preset 2	Bipolar analog input	
1	O : Stop (Disable) C : Run (Enable)	O : Speed Preset 1 C : Speed Preset 2	O : Speed Preset 1, 2 C : Speed Preset 3	O : Speed Preset 1,2,3 C : Speed Preset 4	
2	O : Stop (Disable) C : Run (Enable)	<b>Digi input 2</b>	<b>Digi input 3</b>	<b>Analog input</b>	<b>Preset value</b>
		Open	Open	Open	Preset speed 1
		Closed	Open	Open	Preset speed 2
		Open	Closed	Open	Preset speed 3
		Closed	Closed	Open	Preset speed 4
		Open	Open	Closed	Preset speed 5
		Closed	Open	Closed	Preset speed 6
		Open	Closed	Closed	Preset speed 7
Closed	Closed	Closed	Preset speed 8		
3	O : Stop (Disable) C : Run (Enable)	O : Forward C : Reverse	O : Bipolar analog input C : Speed Preset 1	Bipolar analog input	
4	O : Stop (Disable) C : Run (Enable)	O : Forward C : Reverse	2 <sup>nd</sup> Analog Input (eg varies torque limit)	Bipolar analog input	
5	O : Stop (Disable) C : Run (Enable)	O : Forward C : Reverse	<b>Digi input 3</b>	<b>Analog input</b>	<b>Preset value</b>
			Open	Open	Preset speed 1
			Closed	Open	Preset speed 2
			Open	Closed	Preset speed 3
Closed	Closed	Preset speed 4			
6	O : Stop (Disable) C : Run (Enable)	O : Forward C : Reverse	External trip input : O : Trip C : OK	Bipolar analog input	
7	O : Stop (Disable) C : Run Forward	O : Stop (Disable) C : Run Reverse	O : Bipolar analog input C : Speed Preset 1	Bipolar analog input	
8	O : Stop (Disable) C : Run Forward	O : Stop (Disable) C : Run Reverse	O : Speed Preset 1 C : Bipolar analog input	Bipolar analog input	
9	O : Stop (Disable) C : Run Forward	O : Stop (Disable) C : Run Reverse	<b>Digi input 3</b>	<b>Analog input</b>	<b>Preset value</b>
			Open	Open	Preset speed 1
			Closed	Open	Preset speed 2
			Open	Closed	Preset speed 3
Closed	Closed	Preset speed 4			
10	O : Stop (Disable) C : Run Forward	O : Stop (Disable) C : Run Reverse	External trip input : O : Trip C : OK	Bipolar analog input	
11	O : Stop (Disable) C : Run (Enable)	O : Bipolar analog input C : Speed Preset 1	External trip input : O : Trip C : OK	Bipolar analog input	
12	O : Stop (Disable) C : Run (Enable)	O : Speed Preset 1 C : Bipolar analog input	External trip input : O : Trip C : OK	Bipolar analog input	
13	Normally Open (NO) Momentarily Close to Run	Normally Closed (NC) Momentarily Open to Stop	O : Bipolar analog input C : Speed Preset 1	Bipolar analog input	
14	Normally Open (NO) Momentarily Close to Run Forward	Normally Closed (NC) Momentarily Open to Stop	Normally Open (NO) Momentarily Close to Run Reverse	Bipolar analog input	
15	O : Stop (Disable) C : Run (Enable)	O : Forward C : Reverse	O : Decel ramp 1 C : Decel ramp 2	Bipolar analog input	
16	O : Stop (Disable) C : Run (Enable)	O : Forward C : Reverse	O : Decel ramp 1 C : Decel ramp 2	O : Speed Preset 1 C : Speed Preset 2	
17	O : Stop (Disable) C : Run (Enable)	O : Forward C : Reverse	O : Terminal mode C : Keypad mode	Bipolar analog input (when in terminal mode)	
18	O : Stop (Disable) C : Run (Enable)	<b>Digi input 2</b>	<b>Digi input 3</b>	<b>Preset value</b>	O : Terminal mode C : Keypad mode
		Open	Open	Preset speed 1	
		Closed	Open	Preset speed 2	
		Open	Closed	Preset speed 3	
Closed	Closed	Preset speed 4			
19	O : Stop (Disable) C : Run (Enable)	O : Bipolar Analog input C : 2nd Analog input	2 <sup>nd</sup> Analog input	Bipolar analog input	
20	O : Stop (Disable) C : Run (Enable)	2 <sup>nd</sup> digital output : Drive healthy = +24V	O : Bipolar analog input C : Speed Preset 1	Bipolar analog input	
21	O : Stop (Disable) C : Run (Enable)	2 <sup>nd</sup> digital output : Drive healthy = +24V	O : Forward C : Reverse	Bipolar analog input	
22	O : Stop (Disable) C : Run (Enable)	2 <sup>nd</sup> digital output : Drive healthy = +24V	External trip input : O : Trip C : OK	Bipolar analog input	

#### Notes :

- When P2-01 = 20, 21 or 22, the 2<sup>nd</sup> digital input is configured as an output, which outputs +24V when the drive is healthy, otherwise 0V

### 3.4 Control Terminal Connections

The User Control terminals are available via an 11-way pluggable connector. All terminals are galvanically isolated, allowing direct connection to other equipment.



Do not connect mains supply voltages to any terminals other than the User relay output. Permanent damage will otherwise result.

All other inputs will withstand up to 30V dc without damage.

The functionality of the inputs and outputs is user configurable. All operating modes are set up via the parameter set.

Up to 100mA can be sourced from the User +24V output and up to 20mA from the analog output.

The control terminals are defined as follows :

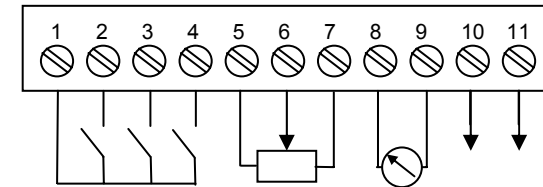

- Terminal 1: +24V, 100mA output. Connected to terminal 5
- Terminal 2: Digital input 1, positive logic. Active when  $8V < V_{in} < 30V$
- Terminal 3: Digital input 2, positive logic. Active when  $8V < V_{in} < 30V$   
2<sup>nd</sup> digital output : 0 / 24V, 10mA max
- Terminal 4: Unipolar analog input, 11-bit (0.05%). 0..10V, 0..20mA, 4..20mA.  
Digital input 3, positive logic. Active when  $8V < V_{in} < 30V$
- Terminal 5: +24V, 100mA output. Connected to terminal 1
- Terminal 6: Bipolar analog input, +/-12-bit (0.025%). 0..24V, 0..10V, -10V...10V
- Terminal 7: 0V (User GND). Connected to terminal 9
- Terminal 8: Analog output, 8-bit (0.25%). 0..10V, 4..20mA.  
Digital output : 0 / 24V, 20mA max
- Terminal 9: 0V (User GND). Connected to terminal 7
- Terminal 10: User relay output. Potential free contacts. 30Vdc 5A, 250Vac 6A
- Terminal 11: User relay output. Potential free contacts. 30Vdc 5A, 250Vac 6A

#### Key control terminal information :

- Maximum input voltage on any terminal 30V dc
- All outputs short circuit proof
- Recommended potentiometer resistance : 10k Ohm
- Digital input response time < 8ms
- Bipolar analog input response time < 16ms. Resolution +/-12 bit (0.025%)
- Second analog input response time < 16ms. Resolution +11 bit (0.05%)
- Analog / Digital output response time < 16ms. Resolution 8 bit (0.25%)

## 4. Operation

### 4.1 Managing the keypad

The drive is configured and its operation monitored via the keypad and display

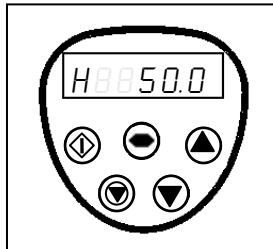

**NAVIGATE:** Used to display real-time information, to access and exit parameter edit mode and to store parameter changes

**UP:** Used to increase speed in real-time mode or to increase parameter values in parameter edit mode

**DOWN:** Used to decrease speed in real-time mode or to decrease parameter values in parameter edit mode

**RESET / STOP:** Used to reset a tripped drive. When in Keypad mode (see below and P1-12 in the parameter section) is used to Stop a running drive.

**START:** When in keypad mode, used to Start a stopped drive or to reverse the direction of rotation if bi-directional keypad mode is enabled (see P1-12 in the parameter section)

**To change a parameter value** press and hold the NAVIGATE key for >1s whilst the drive displays STOP. The display changes to P1-01, indicating parameter 01 in parameter group 1. Press and release the NAVIGATE key to display the value of this parameter. Change to the required value using the UP and DOWN keys. Press and release the NAVIGATE key once more to store the change. Press and hold the NAVIGATE key for >1s to return to real-time mode. The display shows STOP if the drive is stopped or the real-time information (eg speed) if the drive is running.

**To change parameter group**, ensure that extended menu access is enabled then press NAVIGATE, simultaneously pressing and releasing the UP key until the required parameter group is displayed.

### 4.2 Easy startup

1. Connect motor to drive, checking star/delta connection for the voltage rating
2. Enter motor data from motor nameplate :  
P1-07 = motor rated voltage  
P1-08 = motor rated current  
P1-09 = motor rated frequency
3. Enable the drive. The drive automatically carries out a static Auto-tune
4. For high performance vector, set P1-14 = 101, P4-01 = 0, then set P4-02 = 1. The drive automatically carries out a static Auto-tune.

**To operate in terminal mode (default setting)**, connect a switch between terminals 1 and 2 on the user terminal block. Connect a potentiometer (2k2 to 10k) between terminals 5, 6 and 7 with the wiper connected to pin 6. Close the switch to enable the drive. Adjust speed with the potentiometer.

**To operate in keypad mode**, set P1-12 = 1 (uni-directional) or 2 (bi-directional). Place a wire link or switch between terminals 1 and 2 on the user terminal block to enable the drive. Now press START. The drive enables at 0Hz. Press the UP button to increase speed. Press the STOP button to ramp to stop.

*The desired target speed can be preset by pressing STOP whilst the drive is stopped. When the START key is subsequently pressed, drive will then ramp to this speed.*

### 5.3 Group 3 : User feedback control (PID control)

- Not available for 3<sup>EV</sup> Modbus version

P3-01	User PID Proportional Gain	0.1 ... 30.0	2	Higher value used for high inertia. Too high a value gives instability.
P3-02	User PID Integral time constant	0.1s ... 30.0s	1s	Higher value gives slower, more damped response.
P3-03	User PID Differential time constant	0.00s ... 1.00s	0.00	Set to zero (disabled) for most applications.
P3-04	User PID operating mode	0: Direct 1: Inverse	0	If an increasing feedback signal should increase the speed of the motor, set to 'Inverse' mode.
P3-05	User PID reference select	0: Digital 1: Analog	0	Sets the source for the PID control reference signal. When set to 1, the bipolar analog input is used.
P3-06	User PID digital reference	0 ... 100%	0.0 %	Sets the preset reference used when P3-05 = 0.
P3-07	User PID controller output high limit	P3-08 to 100% of control range	100%	Preset PID controller output upper (speed) limit. 100% = P1-01.
P3-08	User PID controller output low limit	0 to P3-07	0	Preset PID controller output lower (speed) limit. 100% = P1-01.
P3-09	User PID output limit control	0: Digital output limits 1: Analog upper limit 2: Analog lower limit 3: PID output + Bipolar Analog input	0	When set to 1 or 2, the bipolar analog input is used to vary the PID output limit between P1-02 and P1-01. When set to 3, the bipolar analog input value will be added to the PID output.
P3-10	User PID feedback select	0: 2 <sup>nd</sup> Analog input 1: DC bus voltage	0	When set to 1, the DC bus voltage is used for PID feedback (100V=100%). This value is measured internally.

### 5.4 Group 4 : High performance Motor control

P4-01	Control mode	0: Speed control (vector) 1: Torque control (vector) 2: Speed control (V/F)	2	Whenever changing control mode, ensure that an Auto-tune (P4-02) is always carried out for best motor performance.
P4-02	Motor parameter auto-tune	0: Disable 1: Enable	0	When set to 1, drive immediately carries out a static (non-rotating) motor parameter measurement operation to configure the motor parameters. Parameter P1-07, P1-08 and P1-09 must be set correctly according to the motor nameplate before enabling this function. Auto-tune runs automatically on first enable after parameter default operation and P1-08 was changed. <b>No hardware enable is required.</b>
P4-03	Speed controller Proportional Gain	0 ... 4096 (internal value)	Drive rating	Higher value used for high inertia. Too high a value gives instability.
P4-04	Speed controller Integral time constant	0.000 ... 1.000s	0.05s	Higher value gives slower, more damped response.
P4-05	Speed controller filter time constant	0.001 ... 0.100s	0.005s	Higher value gives slower response to load changes. Too small a value gives instability.
P4-06	Torque reference select	0: Preset value 1: Bipolar analog input 2: 2 <sup>nd</sup> analog input 3: Modbus ref (Optional)	0	Used when in vector control mode to set a maximum torque limit. Note that option 3 is not available in the standard OD Plus.
P4-07	Maximum torque limit / Torque reference	0 ... 200%	200%	Preset torque ref when P4-01 = 1. Max torque limit when P4-01 = 0.
P4-08	Minimum torque limit	0...150%	0	Defines the minimum limit for the motor shaft torque
P4-09	V/F characteristic adjustment frequency	0 ... P1-09	0.0Hz	Sets the frequency at which the adjustment voltage (P4-10) is applied.
P4-10	V/F characteristic adjustment voltage	0 ... P1-07	0	Adjusts the motor voltage by this value at frequency set in P4-09.

P2-26	Modbus RTU baudrate option	9.6kbps to 115.2kbps	115.2	Modbus RTU communication network baudrate. Only available if optional Modbus plug-in installed
P2-27	Drive communication address	0: Disable 1..63	1	Distinct drive address used for all drive serial communications.
P2-28	Master / Slave mode select	0: Slave mode 1: Master mode	0	When in Master mode, the drive transmits its operational status via the serial data link. Used to control slave drives via the serial link. P2-27 must be 1 for Master mode.
P2-29	Digital speed reference preset scaling factor	0...500%, steps of 0.1%	100%	The digital speed reference input to the drive is scaled by this factor when P2-35 = 1. Operates on references originating from the serial data link. Can be used as an electronic gearbox for Master / Slave applications.
P2-30	Bipolar analog input format	0..24V, 0..10V, -10..10V	0..24V	Configures the analog input format to match that of the reference signal connected to terminal 6
P2-31	Bipolar analog input scaling	0...500%	100%	Scales the analog input by this factor. Set to 200% to give full speed range control with 0..5V input (when P2-30 = 0..10V)
P2-32	Bipolar analog input offset	0..100.0%	0%	Sets the offset from zero at which speed starts to ramp up. Value is "%" of the full scale input voltage.
P2-33	2 <sup>nd</sup> analog input format	0 / 24V (digital input) 0..10V, 4..20mA, 0..20mA	0 / 24V	Determines the format of the 2 <sup>nd</sup> analog input. Selecting 0 / 24V sets up the input as a digital input.
P2-34	2 <sup>nd</sup> analog input scaling	0...500%	100%	Scales the 2 <sup>nd</sup> analog input by the factor set in this parameter.
P2-35	Digital speed reference scaling control	0: Disabled (no scaling) 1: Scaling set by preset value in P2-29 2: Slave speed scaled by preset value in P2-29, then bipolar analog input added as offset 3: Slave speed scaled by preset value in P2-29 and by bipolar analog input	0	Only active in keypad control mode and usually used in a Master/Slave network application. When P2-35 = 1, actual speed = Digital speed * P2-29. When P2-35 = 2, actual speed = (Digital speed x P2-29) + bipolar analog input Max analog input is equal to P1-01 When P2-35 = 3, actual speed = (Digital speed x P2-29) x bipolar analog input Analog input scales 0% ... 200%
P2-36	Analog output format	0..10V 4..20mA 10..0V 20..4mA	0..10V	Determines the analog output format. Min load impedance in voltage mode 1k Ohm. Max load impedance in current mode 1k Ohm.
P2-37	Extended menu access code define	0...9999	101	Defines the extended menu access code used in P1-14.
P2-38	Parameter Lock	0: Unlocked 1: Locked	0	When locked, all parameter changes are prevented.
P2-39	Hours run clock	0 to 99999 hours	Read only	Indicates the number of hours the drive has been running since new.
P2-40	Drive type / rating	" 0.37", "0 230": 3 <sup>GV</sup> 230V 0.37kW "HP 20", "1 460": VTC, 460V 20HP	Read only	Indicates drive power rating, type code and voltage rating. Drive type code indicates 3GV (0), VTC (1) or other drive type

## 5. Drive Configuration

### 5.1 Group 1 : Basic Parameters

Par.	Description	Range	Default	Explanation
P1-01	Max speed limit	P1-02 to P1-09 x 5 (up to 2000Hz max)	50 Hz	Sets the maximum speed limit. Display of Hz or rpm dependent on P1-10. Maximum speed limit dependent on switching frequency: Max Limit = P2-24 / 16.
P1-02	Min speed limit	0 to P1-01	0 Hz	Minimum speed limit. Hz or rpm display depending on P1-10.
P1-03	Accel ramp time	0 to 3000s	5.0s	Time to ramp from 0 to rated frequency (P1-09)
P1-04	Decel ramp time	0 to 3000s	5.0s	Time to ramp from rated frequency (P1-09) to 0. When P1-04 = 0, the ramp is varied dynamically to give the fastest possible ramp to STOP.
P1-05	Stop mode select	0: Ramp to stop 1: Coast to stop 2: Ramp to stop	0	If the supply is lost and P1-05 = 0 then the drive will try to continue running by reducing the speed of the load using the load as a generator. If P1-05 = 2, the drive ramps on 2nd decel ramp P2-25 to stop.
P1-06	Energy Optimisation	0: Disable 1: Enable	0	When enabled, automatically reduces applied motor voltage on light load. Used in V/F mode only.
P1-07	Motor rated voltage	20V to 250V 20V to 500V	230V 400V (460V)	Set to motor rated voltage from nameplate. Range limited to 250V for 230V drives
P1-08	Motor rated current	20% to 100% of drive rated current	Drive rating	Set to motor rated current from nameplate (Amps)
P1-09	Motor rated frequency	25 to 2000Hz	50Hz (60Hz)	Set to motor rated frequency from nameplate (Hz). Maximum limit dependent on switching frequency: Max Limit = P2-24 / 16.
P1-10	Motor rated speed	0 to 60,000rpm	0	When 0, drive operates in Hz. Upper limit set to 60 x P1-09. This value usually can be found in the motor nameplate.
P1-11	Preset speed 1	-P1-01 to P1-01	50Hz (60Hz)	Sets jog / preset speed at which drive runs when preset speed 1 selected via digital inputs. (see also P2-01)
P1-12	Terminal / Keypad control of drive	0: Terminal control 1: Keypad control (Fwd only) 2: Keypad control (Fwd and Rev) 3: Enable User PID 4: Modbus network control (Optional)	0	0 : Terminal control 1 : Uni-direction keypad control. 2 : Bi-directional keypad control. Keypad START button toggles between forward and reverse. 3 : User PID (feedback control) active, setup in parameter group 3. 4 : Drive controlled via integrated Modbus RTU interface. Note that this is an upgrade option and is not available in the standard OD Plus.
P1-13	Trip Log	Last 4 trips stored	-	Latest 4 trips stored. Most recent trip displayed first.
P1-14	Extended Menu Access code	0 to 30000	0	Permits access to extended menu when P1-14 = P2-37. Default access value = 101.

#### Notes:

- Default parameter values for Horse Power rated drives are shown in brackets

5.2 Group 2 : Extended Parameters

Par.	Description	Range	Default	Explanation
P2-01	Digital input function select	0 to 22	0	Defines the function of the digital inputs. See sections 5.5 ... 5.7 on pages 16...18 for more details.
P2-02	Preset speed 2	-P1-01 to P1-01	0 Hz	Sets jog / preset speed 2
P2-03	Preset speed 3	-P1-01 to P1-01	0 Hz	Sets jog / preset speed 3
P2-04	Preset speed 4	-P1-01 to P1-01	0 Hz	Sets jog / preset speed 4
P2-05	Preset speed 5	-P1-01 to P1-01	0 Hz	Sets jog / preset speed 5
P2-06	Preset speed 6	-P1-01 to P1-01	0 Hz	Sets jog / preset speed 6
P2-07	Preset speed 7	-P1-01 to P1-01	0 Hz	Sets jog / preset speed 7
P2-08	Preset speed 8	-P1-01 to P1-01	0 Hz	Sets jog / preset speed 8
P2-09	Skip frequency	P1-02 to P1-01	0	Centre point of skip frequency band set up in conjunction with P2-10.
P2-10	Skip frequency band	0 to P1-01	0 (disable)	Width of skip frequency band centred on frequency set in P2-09.
P2-11	Analog output function select	(Digital output mode) 0: Drive enabled 1: Drive healthy 2: Motor at target speed 3: Motor speed > 0 4: Motor speed > limit 5: Motor torque > limit 6: 2 <sup>nd</sup> Analog in > limit  (Analog output mode) 7: Motor speed 8: Motor torque 9: Motor power (kW) 10: Motor current	7	For values 0 to 6, analog output functions as a digital output. (0V or 24V output) The control limit used for settings 4, 5 and 6 is defined in P2-12(h) and P2-12(L). For values between 7 and 9, the output is analog signal, operating between 0..10V or 4..20mA. (as set in P2-36) Full scale analog output results at max speed, 2x rated motor torque (motor rated output torque), rated power of the drive or 2x rated motor current.
P2-12 (h)	Digital output control high limit	Speed : 0..100% (100% = max speed) Torque : 0..200% (100% = rated torque) PID feedback : 0..100% (100% = max 2 <sup>nd</sup> analog input)	100%	Digital output state set to logic 1 when selected value in P2-11 larger than this limit. Limit in P2-12 relates to speed if P2-11 = 4, to motor torque if P2-11 = 5 or to the PID feedback value (2 <sup>nd</sup> analog input) if P2-11 = 6.
P2-12 (L)	Digital output control low limit	0 ... P2-12(h)	100%	Digital output state back to logic 0 when selected value in P2-11 less than or equal to this limit. (P2-11 = 4,5 or 6)
P2-13	User relay output function select	0: Drive Enabled 1: Drive healthy 2: Motor at target speed 3: Motor speed > 0 4: Motor speed > limit 5: Motor torque > limit 6: 2 <sup>nd</sup> Analog in > limit	1	If P2-15 = 0 (Normally Open), the relay contacts are closed when the selected condition is fulfilled. If P2-15 = 1 (Normally Closed), the relay contacts are open when the selected condition is fulfilled.
P2-14 (h)	User relay output control high limit	Speed : 0..100% (100% = max speed) Torque : 0..200% (100% = rated torque) PID feedback : 0..100% (100% = max 2 <sup>nd</sup> analog input)	100%	User relay output closes (P2-15=0) when selected value in P2-13 larger than this limit. Limit in P2-14 relates to speed if P2-13 = 4, to motor torque if P2-13 = 5 or to the PID feedback value (2 <sup>nd</sup> analog input) if P2-13 = 6.
P2-14 (L)	User relay output control low limit	0 ... P2-14(h)	100%	Digital output state back to logic 0 when selected value in P2-13 less than or equal to this limit. (P2-13 = 4,5 or 6)
P2-15	Relay output mode	0: Normally Open (NO) 1: Normally Closed (NC)	0 (N.O.)	The drive must be powered up for the relay contacts to be closed.

P2-16	Zero Speed holding time	0 ... 60s	0.2s	Determines the time for which the zero speed is held on the output before disabling the drive.
P2-17	Start mode select	Edgr-r : Close digital input 1 after power up to start drive  Auto-0 : drive runs whenever digital input 1 is closed  Auto-1...5 : as Auto-0, except 1..5 attempts to restart after a trip	Auto-0	When set to Edge-r, if drive is powered up with digital Input 1 closed (enabled), drive will not run. The switch (digital input 1) must be opened and closed after power up or after a clearing a trip for the drive to run. When set to Auto-0, drive will run whenever digital input 1 is closed (if not tripped). Auto-1...5 makes 1...5 attempts to automatically restart after a trip (20s between attempts in default). Drive must be powered down to reset the counter.
P2-18	Spin Start Enable <i>(Not available for 3<sup>6V</sup> Modbus version)</i>	0: Disable 1: Enable	0	When enabled, drive detects motor speed and starts driving the motor from this speed. A short delay of approx 1s will result after enabling the drive before speed is detected. (Not valid in torque control mode)
P2-19	Keypad restart mode	0: Minimum speed 1: previous speed 2: Min-speed (Auto-r) 3: prev. speed (Auto-r)	1	If set to 0 or 2, drive will always start from minimum speed. If set to 1 or 3, drive ramps up to the operating speed prior to the last STOP command. If set to 2 and 3, the status of digital input 1 controls drive to start or stop. The start and stop button will not work in this case.
P2-20	Standby mode	0: Disable 1 ... 60s	0	If P2-20 >0, drive enters standby mode (disables output) if zero speed is maintained for the time specified in P2-20. If P2-16 >0, this function is disabled.
P2-21	Display scaling factor	0.000 to 30.000	0.000	Disabled if set to zero. The variable selected in P2-22 is multiplied by this factor and displayed as a real-time value on the drive, in addition to speed, current and power.
P2-22	Display scaling source	0: 2 <sup>nd</sup> analog input 1: Speed 2: Motor output torque	0	Selects the variable to be scaled by the factor set in P2-21.
P2-23	Brake circuit enable	0: Disable 1: Enable + lo power 2: Enable + hi power 3: Enable, no protection	0	Enables the internal brake chopper Overload protection in software when set to 1 or 2. See rating tables for resistor sizing guidelines.
P2-24	Effective switching frequency	S1, S2 230V : 4..32kHz S2 400V : 4..32kHz S3 400V : 4..24kHz S4 400V : 4..24kHz S5 400V : 4..16kHz S6 400V : 4..16kHz  *: Max limit dependent on power rating	16 kHz 8 kHz 4 kHz 4 kHz 4 kHz	Effective power stage switching frequency. Improved acoustic noise and output current waveform occurs with increasing switching frequency at the expense of increased losses within the drive. "Auto" selects minimum possible switching frequency for the speed range selected (P2-24 must be 16x P1-01 or greater)
P2-25	Second deceleration ramp time	0s ... 3000s	30s	Selected automatically on mains loss if P1-05 = 0 or 2. Can also be selected via digital inputs during operation (see section 5.5 and 5.6)